

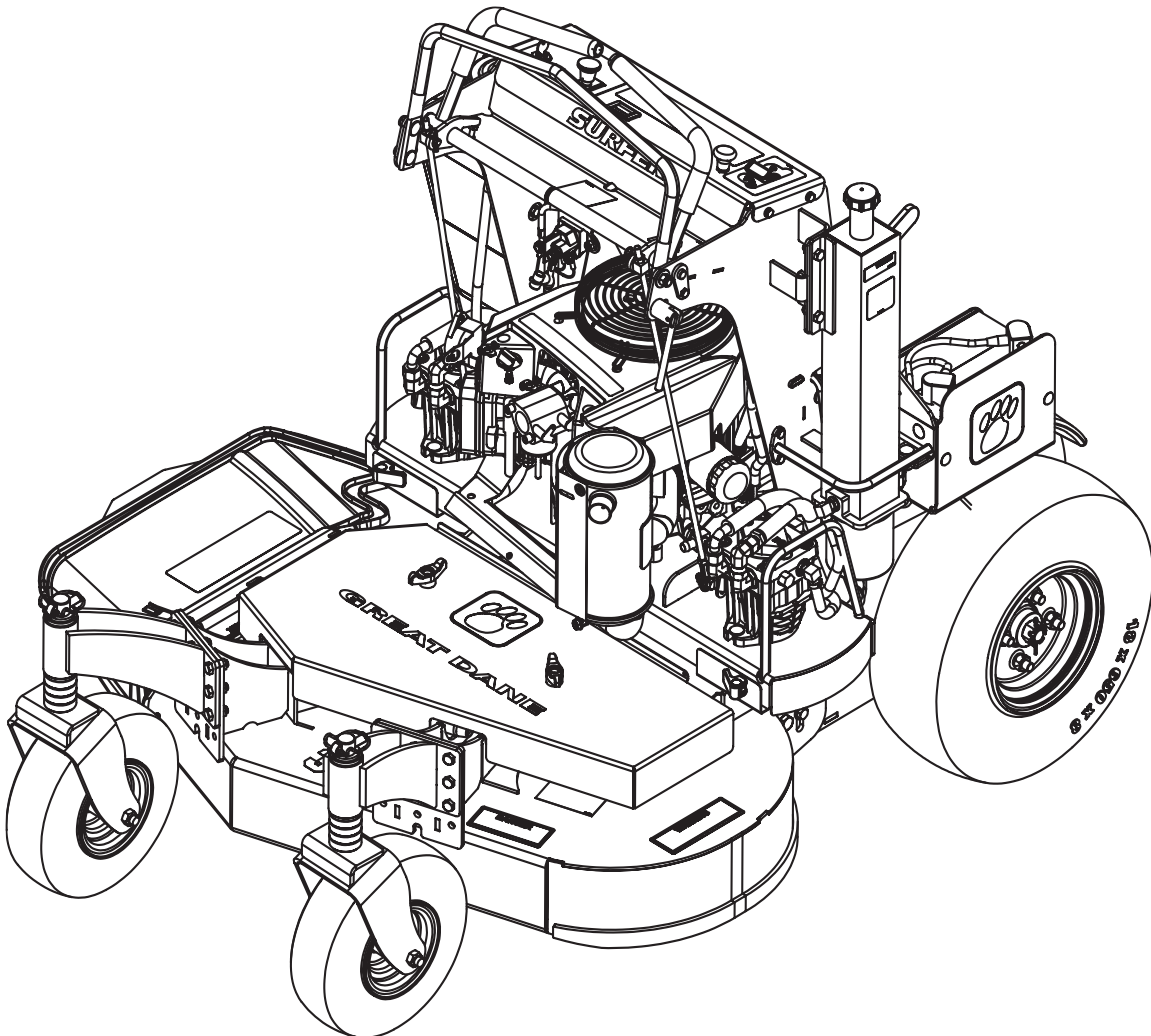

**Saving
you time.**

**Great Dane[®]
GSRKA1934S**



201018

10/02/2007



WARNING: The Engine Exhaust from this product contains chemicals known to the State of California to cause cancer, birth defects or other reproductive harm.

California Proposition 65 Warning

All information, illustrations and specifications in this manual are based on the latest information at the time of publication. The right is reserved to make changes at any time without notice.

COPYRIGHT© 2007
Auburn Consolidated Industries, Inc.
All rights reserved

Great Dane, Chariot, Brutus, Scamper, Surfer, and Super Surfer are registered trademarks of Auburn Consolidated Industries, Inc.

Introduction

Using Your Operator's Manual

This manual is an important part of your machine and should remain with the machine when you sell it.

Use the safety and operating information in the machine operator's manual to operate and service the machine safely and correctly.

An engine manufacturer's owner's manual has been provided with your machine. This will provide maintenance and troubleshooting information for the engine installed in your machine.

Specifications and design are subject to change without notice.

Special Messages

Your manual contains special messages to bring attention to potential safety concerns, machine damage as well as helpful operating and servicing information. Please read all the information carefully to avoid injury and machine damage.



CAUTION: Avoid injury! This symbol and text highlight potential hazards or death to the operator or bystanders that may occur if the hazards or procedures are ignored.

IMPORTANT: Avoid Damage! This text is used to tell the operator of actions or conditions that might result in damage to the machine.

NOTE: General information is given throughout the manual that may help the operator in the operation or service of the machine.

Product Identification

Record Identification Numbers

Surfer

GSRKA1934S Serial Number (637110001-)

If you need to contact an Authorized Service Center for information on servicing, always provide the product model and serial numbers.

You will need to locate the model and serial numbers for the machine and for the engine of your machine and record the information in the spaces provided.

SAFETY LABELS

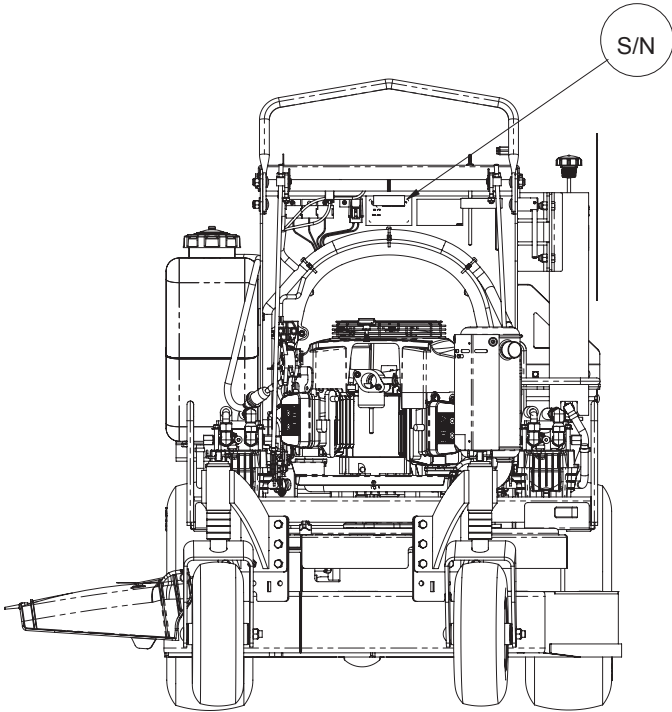

Safety-Alert Symbol

The machine safety labels shown in this section are placed in important areas on your machine to draw attention to potential safety hazards.

On your machine safety labels, the words DANGER, WARNING, and CAUTION are used with this safety-alert symbol. DANGER identifies the most serious hazards. The operator's manual also explains any potential safety hazards whenever necessary in special safety messages that are identified with the word, CAUTION, and the safety-alert symbol.

Safety Labels

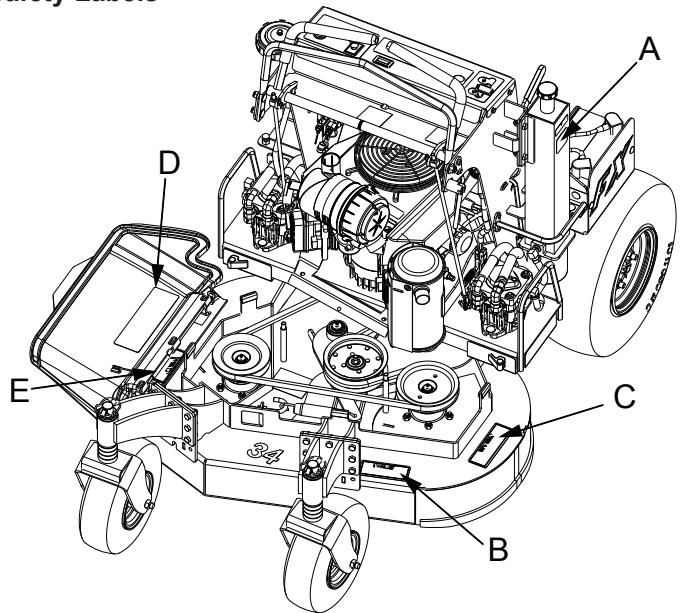

WARNING (A)
Hot Surface.

DATE OF PURCHASE:

DEALER NAME:

DEALER PHONE:

PRODUCT IDENTIFICATION NUMBER:

Model Number

Serial Number

ENGINE MODEL, SPECIFICATION, AND SERIAL NUMBER:

Model Number

Specification

Serial Number

Safety Labels

Understanding The Machine Safety Labels

SAFETY LABELS



WARNING (B)

To avoid injury from rotating belts, keep all shields and guards in place.



DANGER (C)

To avoid injury from rotating blades, stay clear of deck edge.

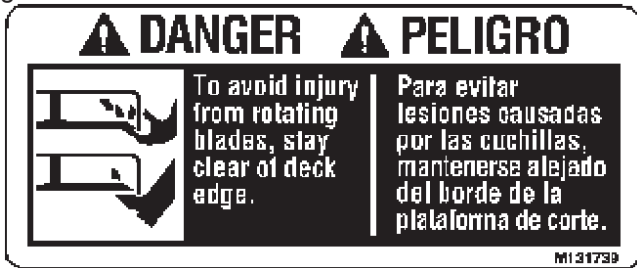

DANGER (D)

To avoid injury from rotating blades and thrown objects, stay clear of deck edge and keep others away. Do not mow without discharge chute or entire grass catcher in place.

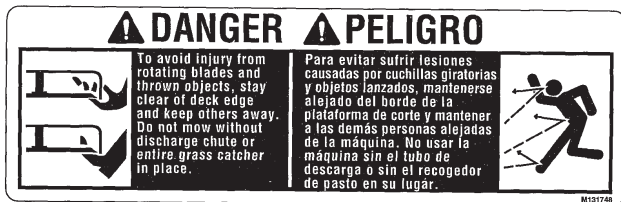

DANGER (E)

Do not mow without discharge chute or entire grass catcher in place.

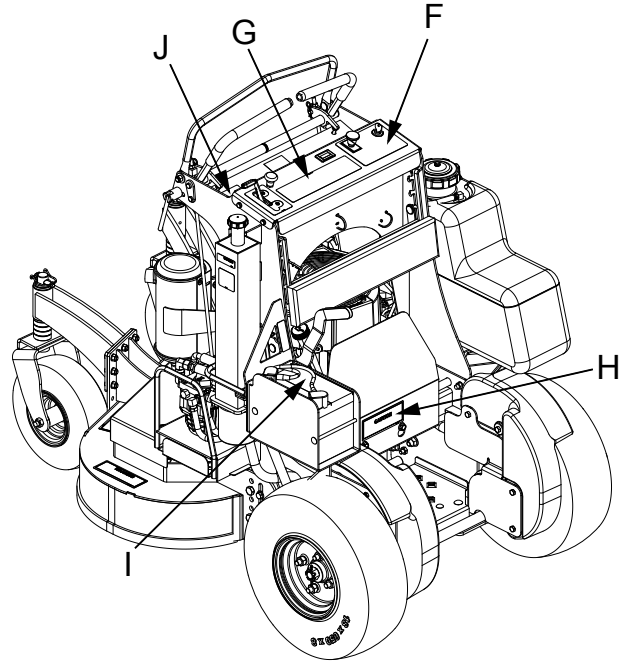

CAUTION: (F)

Before operating read operators manual and safety instructions.



CAUTION: HELP AVOID INJURY (G)

- Operator training required
- Read operator's manual
- Keep shields in place
- Never carry riders
- Keep people a safe distance away
- Maintain all safety devices
- Before leaving machine:
 - Stop engine
 - Set park brake
 - Remove key

SAFETY

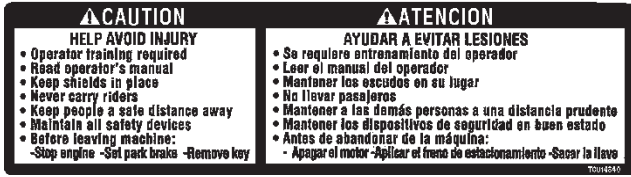

CAUTION (H)

Be safe! To avoid a fire hazard remove all leaves, grass and debris from engine, hydro pumps and motors, pulleys, belts, hoses, engine deck and cutter deck.



DANGER/POISON (I)

- Shield Eyes: Explosive gases can cause blindness or injury.
- NO
- Sparks
- Flames
- Smoking
- Sulfuric acid can cause blindness or severe burns.
- Flush eyes immediately with water. Get medical help fast.
- Keep out of reach of children.
- Do not tip.
- Do not open battery.

WARNING (J)

To avoid injury from tipover, drive across slopes, not up and down. If machine stops going uphill, stop blades and back down slowly.



Emission Control System Certification Label

NOTE: Tampering with emission controls and components by unauthorized personnel may result in severe fines or penalties. Emission controls and components can only be adjusted by EPA and/or CARB authorized service centers. Contact your Great Dane Equipment Retailer concerning emission controls and component questions.

The presence of an emissions label signifies that the en-

gine has been certified with the United States Environmental Protection Agency (EPA) and/or California Air Resources Board (CARB).

The emissions warranty applies only to those engines marketed by Great Dane that have been certified by the EPA and/or CARB; and used in the United States and Canada in off-road mobile equipment.

Emission Compliance Period

If your engine has the emission compliance category listed on the emission control system certification or air index label, this indicates the number of operating hours for which the engine has been certified to meet EPA and/or CARB emission requirements. The following table provides the engine compliance period in hours associated with the category found on the certification label.

Agency	Category	Hours
EPA	C	250
EPA	B	500
EPA	A	1000
CARB	Moderate	125
CARB	Intermediate	250
CARB	Extended	500

Certification

Your product has been tested and evaluated by the manufacturer and conforms with American National Standard B-71.4, "Safety Specifications" for commercial turf care equipment.

Safety

Operator Training Required

- Read the operator's manual and other training material. If the operator or mechanic cannot read English, it is the owner's responsibility to explain this material to them. This publication is available in other languages.
- Become familiar with the safe operation of the equipment, operator controls, and safety signs.
- All operators and mechanics should be trained. The owner of the machine is responsible for training the users.
- Never let children or untrained people operate or service the equipment. Local regulations may restrict the age of the operator.
- The owner/user can prevent and is responsible for accidents or injuries occurring to themselves, other people, or property.
- Operate the machine in an open, unobstructed area under the direction of an experienced operator.

Preparation

- Evaluate the terrain to determine what accessories and attachments are needed to properly and safely perform

SAFETY

the job. Only use accessories and attachments approved by the manufacturer.

- Wear appropriate clothing including hard hat, safety glasses and hearing protection. Long hair, loose clothing or jewelry may get tangled in moving parts.
- Inspect the area where the equipment is to be used and remove all objects such as rocks, toys and wire which can be thrown by the machine.
- Use extra care when handling gasoline and other fuels. They are flammable and vapors are explosive.
 - a. Use only an approved container.
 - b. Never remove gas cap or add fuel when engine is running. Do not smoke.
 - c. Never refuel or drain the machine indoors.
- Check that the operator's presence controls, safety switches and shields are attached and functioning properly. Do not operate unless they are functioning properly.

Operating Safely

- Never run an engine in an enclosed area where dangerous carbon monoxide fumes can collect.
- Only operate in good light, keeping away from holes and hidden hazards.
- Be sure all drives are in neutral and parking brake is engaged before starting engine. Only start engine from the operator's position. Use seat belts if provided.
- Slow down and use extra care on hillsides. Be sure to travel in the recommended direction on hillsides. For this machine, drive across hillsides, not up and down. Turf conditions can affect the machine's stability. Use caution while operating near drop-offs.
- Slow down and use caution when making turns and when changing directions on slopes.
- Never raise deck with the blades running.
- Never operate with the PTO shield, or other guards, not securely in place. Be sure all interlocks are attached, adjusted properly, and functioning properly.
- Never operate with the discharge deflector raised, removed or altered, unless using a grasscatcher. Do not operate mower without discharge chute or entire grasscatcher in place.
- Do not change the engine governor setting or overspeed the engine. Operating the engine at excessive speed can increase the hazard of personal injury.
- Stop on level ground, lower implements, disengage drives, engage parking brake, and shut off engine before leaving the operator's position for any reason including emptying the grasscatchers or unclogging the chute.
- Stop equipment and inspect blades after striking objects or if an abnormal vibration occurs. Make necessary repairs before resuming operations.
- Keep hands and feet away from the cutting units.
- Look behind and down before backing up to be sure of a clear path.
- Never carry passengers and keep pets and bystanders

away.

- Slow down and use caution when making turns and crossing roads and sidewalks. Stop blades if not mowing. Watch for traffic when operating near or crossing roadways.
- Be aware of the mower discharge direction and do not point it at anyone.
- Do not operate the machine while under the influence of alcohol or drugs.
- Use care when loading or unloading the machine into or off of a trailer or truck.
- Use care when approaching blind corners, shrubs, trees, or other objects that may obscure vision.
- Inspect machine before you operate. Be sure hardware is tight. Repair or replace damaged, badly worn, or missing parts. Be sure guards and shields are in good condition and fastened in place. Make any necessary adjustments before you operate.
- Before using, always visually inspect to see that the blades, blade bolts and the mower assembly are not worn and damaged. Replace worn and damaged blades and bolts in sets to preserve balance.
- Keep safety labels visible when installing accessories and attachments.
- Do not wear radio or music headphones. Safe service and operation require your full attention.
- When machine is left unattended, stored, or parked, lower the mower deck unless a positive mechanical lock is used.

Using a Spark Arrestor

The engine in this machine is not equipped with a spark arrestor muffler. It is a violation of California Public Resource Code Section 4442 to use or operate this engine on or near any forest-covered, brush-covered or grass-covered land unless the exhaust system is equipped with a spark arrestor meeting any applicable local or state laws. Other states or federal areas may have similar laws.

A spark arrestor for your machine may be available from your authorized dealer. An installed spark arrestor must be maintained in good working order by the operator.

Checking Mowing Area

- Evaluate the terrain to determine what accessories and attachments are needed to properly and safely perform the job.
- Clear mowing area of objects that might be thrown. Keep people and pets out of mowing area.
- Study mowing area. Set up a safe mowing pattern. Do not mow where traction or stability is doubtful.
- Test drive area with mower lowered but not running. Slow down when you travel over rough ground.

SAFETY

Parking Safely

1. Stop machine on a level surface, not on a slope.
2. Disengage mower blades.
3. Lock the park brake.
4. Stop the engine.
5. Remove the key.
6. Wait for engine and all moving parts to stop before you leave the operator's station.
7. Close fuel shut-off valve, if your machine is equipped.
8. Disconnect the negative battery cable or remove the spark plug wire (for gasoline engines) before servicing the machine.

ROTATING BLADES ARE DANGEROUS!

HELP PREVENT SERIOUS OR FATAL ACCIDENTS:



- Rotating blades can cut off arms and legs, and throw objects. Failure to observe safety instructions could result in serious injury or death.
- Keep hands, feet and clothing away from mower deck when engine is running.
- Be alert at all times, drive forward carefully. People, especially children can move quickly into the mowing area before you know it.
- Do not mow in reverse.
- Shut off blades when you are not mowing.
- Park machine safely before leaving the operator station for any reason including emptying the catchers or unplugging the chute.

PROTECT CHILDREN!



- Death or serious injury can occur when young children associate having fun with a lawn mowing machine simply because someone has given them a ride on a machine.
- Children are attracted to lawn mowing machines and mowing activities. They don't understand the dangers of rotating blades or the fact that the operator is unaware of their presence.
- Children who have been given rides in the past may suddenly appear in the mowing area for another ride and be run over or backed over by the machine.
- Tragic accidents with children can occur if the operator is not alert to the presence of children, especially when a child approaches a machine from behind. Before and while backing up, stop mower blades and look down and behind the machine carefully, especially for children.
- Never carry children on a machine or attachment, even with the blades off. Do not tow children in a cart or trailer. They can fall off and be seriously injured or interfere with safe machine operation.
- Never use the machine as a recreational vehicle or to entertain children.
- Never allow children or an untrained person operate the machine. Instruct all operators not to give children a ride on the machine or in an attachment.
- Keep children indoors, out of the mowing area, and in the watchful eye of a responsible adult, other than the operator, when a mower is being operated.
- Stay alert to the presence of children. Never assume that children will remain where you last saw them. Turn the machine off if a child enters the work area.

Avoid Tipping

- Slopes are a major factor related to loss-of-control and tip-over accidents, which can result in severe injury or death. Operation on all slopes requires extra caution.
- Mow across slopes, not up and down.
- Watch for holes, ruts, bumps, rocks, or other hidden objects. Uneven terrain could overturn the machine. Tall grass can hide obstacles.

SAFETY

- Choose a low ground speed so you will not have to stop or shift while on a slope.
- Do not mow or operate machine on wet grass. Tires may lose traction. • • • Tires may lose traction on slopes even though the brakes are functioning properly.
- Avoid starting, stopping or turning on a slope. If the tires lose traction, disengage the blades and proceed slowly, straight down the slope.
- Keep all movement on slopes slow and gradual. Do not make sudden changes in speed or direction, which could cause the machine to roll over.
- Use extra care while operating machine with grass-catchers or other attachments, they can affect stability of the machine. Do not use on steep slopes.
- Do not mow near drop-offs, ditches, embankments, or bodies of water. The machine could suddenly roll over if a wheel goes over the edge or the edge caves in.
- Follow the manufacturer's recommendations for wheel weights or counterweights for added stability when operating on slopes or using front or rear mounted attachments. Remove weights when not required.
- Drive machine very slowly and avoid quick stops when attachment is removed.
- Transport machine with decks lowered to improve stability.

Keep Riders Off

- Only allow the operator on the machine. Keep riders off.
- Riders on the machine or attachment may be struck by foreign objects or thrown off the machine causing serious injury.
- Riders obstruct the operator's view resulting in the machine being operated in an unsafe manner.

Avoid High Pressure Fluids

- Hydraulic hoses and lines can fail due to physical damage, kinks, age, and exposure. Check hoses and lines regularly. Replace damaged hoses and lines.
- Hydraulic fluid connections can loosen due to physical damage and vibration. Check connections regularly. Tighten loose connections.
- Escaping fluid under pressure can penetrate the skin causing serious injury. Avoid the hazard by relieving pressure before disconnecting hydraulic or other lines. Tighten all connections before applying pressure.
- Search for leaks with a piece of cardboard. Protect hands and body from high pressure fluids.
- If an accident occurs, see a doctor immediately. Any fluid injected into the skin must be surgically removed within a few hours or gangrene may result. Doctors unfamiliar with this type of injury should reference a knowledgeable medical source.

Checking Wheel Hardware

- A serious accident could occur causing serious injury if wheel hardware is not tight.
- Check wheel hardware tightness often during the first

100 hours of operation.

- Wheel hardware must be tightened to specified torque using the proper procedure anytime it is loosened.

Wear Appropriate Clothing

- Always wear safety goggles, or safety glasses with side shields, and a hard hat when operating the machine.
- Wear close fitting clothing and safety equipment appropriate for the job.
- While mowing, always wear substantial footwear and long trousers. Do not operate the equipment when barefoot or wearing open sandals.
- Wear a suitable protective device such as earplugs. Loud noise can cause impairment or loss of hearing.

Maintenance and Storage

- Never operate machine in a closed area where dangerous carbon monoxide fumes can collect.
- Disengage drives, lower implement, lock parking brake, stop engine and remove key or disconnect spark plug (for gas engines). Wait for all movement to stop before adjusting, cleaning or repairing.
- Clean grass and debris from cutting units, drives, mufflers, and engine to help prevent fires. Clean up oil or fuel spillage.
- Let engine cool before storing and do not store near flame.
- Shut off fuel while storing or transporting. Do not store fuel near flames or drain indoors.
- Park machine on level ground. Never allow untrained personnel to service machine. Understand service procedure before doing work.
- Use jack stands or lock service latches to support components when required. Securely support any machine elements that must be raised for service work.
- Before servicing machine or attachment, carefully release pressure from any components with stored energy, such as hydraulic components or springs.
- Release hydraulic pressure by lowering attachment or cutting units to the ground or to a mechanical stop and move hydraulic control levers back and forth.
- Disconnect battery or remove spark plug (for gas engines) before making any repairs. Disconnect the negative terminal first and the positive last. Reconnect positive first and negative last.
- Use care when checking blades. Wrap the blades or wear gloves, and use caution when servicing them. Only replace blades. Never straighten or weld them.
- Keep hands, feet, clothing, jewelry and long hair away from moving parts. If possible, do not make adjustments with the engine running.
- Charge batteries in an open well ventilated area, away from spark and flames. Unplug charger before connecting or disconnecting from battery. • Wear protective clothing and use insulated tools.
- Keep all parts in good working condition and all hardware tightened. Replace all worn or damaged decals.
- Check grass catcher components and the discharge guard frequently and replace with manufacturer's rec-

SAFETY

recommended parts, when necessary. Grass catcher components are subject to wear, damage, and deterioration which could expose moving parts or allow objects to be thrown.

- Keep all nuts and bolts tight, especially blade attachment bolts, to be sure the equipment is in safe working condition.
- Check brake operation frequently. Adjust and service as required.
- On multi-bladed machines, take care as rotating one blade can cause other blades to rotate.

Prevent Fires

- Remove grass and debris from engine compartment and muffler area, before and after operating machine, especially after mowing or mulching in dry conditions.
- Empty the grass catcher completely before storing.
- Always shut off fuel when storing or transporting machine, if the machine has a fuel shutoff.
- Do not store machine near an open flame or source of ignition, such as a water heater or furnace.
- Check fuel lines, tank, cap, and fittings frequently for cracks or leaks. Replace if necessary.

Tire Safety

Explosive separation of a tire and rim parts can cause serious injury or death:

- Do not attempt to mount a tire without the proper equipment and experience to perform the job.
- Always maintain the correct tire pressure. Do not inflate the tires above the recommended pressure. Never weld or heat a wheel and tire assembly. The heat can cause an increase in air pressure resulting in a tire explosion. Welding can structurally weaken or deform the wheel.
- When inflating tires, use a clip-on chuck and extension hose long enough to allow you to stand to one side and NOT in front of or over the tire assembly.
- Check tires for low pressure, cuts, bubbles, damaged rims or missing lug bolts and nuts.

Handling Fuel Safely

To avoid personal injury or property damage, use extreme care in handling fuel. Fuel is extremely flammable and fuel vapors are explosive:

- Extinguish all cigarettes, cigars, pipes, and other sources of ignition.
- Use only an approved fuel container. Use only non-metal, portable fuel containers approved by the Underwriter's Laboratory (U.L.) or the American Society for Testing & Materials (ASTM). If using a funnel, make sure it is plastic and has no screen or filter.
- Never remove the fuel tank cap or add fuel with the engine running. Allow engine to cool before refueling.
- Never add fuel to or drain fuel from the machine indoors. Move machine outdoors and provide adequate ventilation.
- Clean up spilled fuel immediately. If fuel is spilled on

clothing, change clothing immediately. If fuel is spilled near machine, do not attempt to start the engine but move the machine away from the area of spillage. Avoid creating any source of ignition until fuel vapors have dissipated.

- Never store the machine or fuel container where there is an open flame, spark, or pilot light such as on a water heater or other appliance.
- Prevent fire and explosion caused by static electric discharge. Static electric discharge can ignite fuel vapors in an ungrounded fuel container.
- Never fill containers inside a vehicle or on a truck or trailer bed with a plastic liner. Always place containers on the ground away from your vehicle before fueling.



- Remove fuel-powered equipment from the truck or trailer and refuel it on the ground. If this is not possible, then refuel such equipment with a portable container, rather than from a fuel dispenser nozzle.
- Keep the nozzle in contact with the rim of the fuel tank or container opening at all times until the fueling is complete. Do not use a nozzle lock-open device.
- Never overfill fuel tank. Replace fuel tank cap and tighten securely.
- Replace all fuel container caps securely after use.
- For gasoline engines, do not use gas with methanol. Methanol is harmful to your health and to the environment.

Handling Waste Product and Chemicals

- Waste products, such as, used oil, fuel, coolant, brake fluid, and batteries, can harm the environment and people:
- Do not use beverage containers for waste fluids - someone may drink from them.
- See your local Recycling Center or authorized dealer to learn how to recycle or get rid of waste products.
- A Material Safety Data Sheet (MSDS) provides specific details on chemical products: physical and health hazards, safety procedures, and emergency response techniques. The seller of the chemical products used with your machine is responsible for providing the MSDS for that product.

OPERATING

Operating

Daily Operating Checklist

- Make sure all necessary guards and shields are safely and securely attached. Check for loose, missing, or damaged parts.
- Remove mower deck belt shields. Clean grass and debris from belt area.
- Remove grass and debris from machine and mower deck.
- Remove grass and debris from operator station foot plate, pump drive belt compartment, hydraulic pump and pump mounting plate.
- Test park brake.
- Test safety systems.
- Check battery.
- Check for oil leaks.
- Check engine oil and hydraulic oil levels.
- Check all belts for damage or cracking.
- Check engine air filter.
- Check mower level.
- Adjust cutting height if necessary.
- Check wheel bolt torque. Tighten if necessary.
- Check tire air pressure. Check tires for damage or cracking.
- Check and adjust speed control linkages and lock.

Avoid Damage to Plastic and Painted Surfaces

- Do not wipe plastic parts unless rinsed first.
- Insect repellent spray may damage plastic and painted surfaces. Do not spray insect repellent near machine.
- Be careful not to spill fuel on machine. Fuel may damage surface. Wipe up spilled fuel immediately.
- Prolonged exposure to sunlight will damage the hood surface.

Operator Station Controls

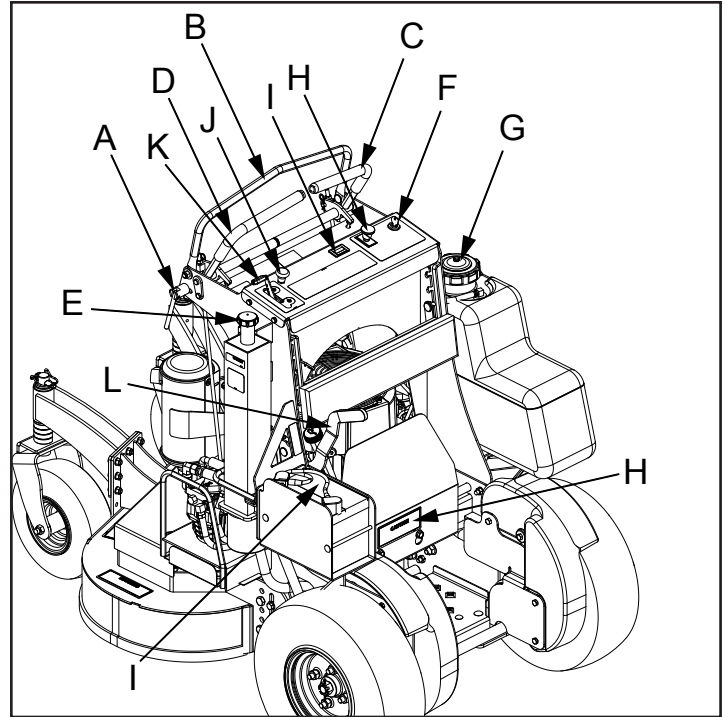

- A-Speed Control Bar Lock
- B-Speed Control Bar
- C-Right Motion Control Lever
- D-Left Motion Control Lever
- E-Hydrostatic Oil Reservoir Cap and Dipstick
- F-Ignition Key Switch
- G-Fuel Tank Cap
- H-PTO Switch
- I-Hour Meter
- J-Choke
- K-Throttle Lever
- L-Park Brake Lever

Miscellaneous Controls

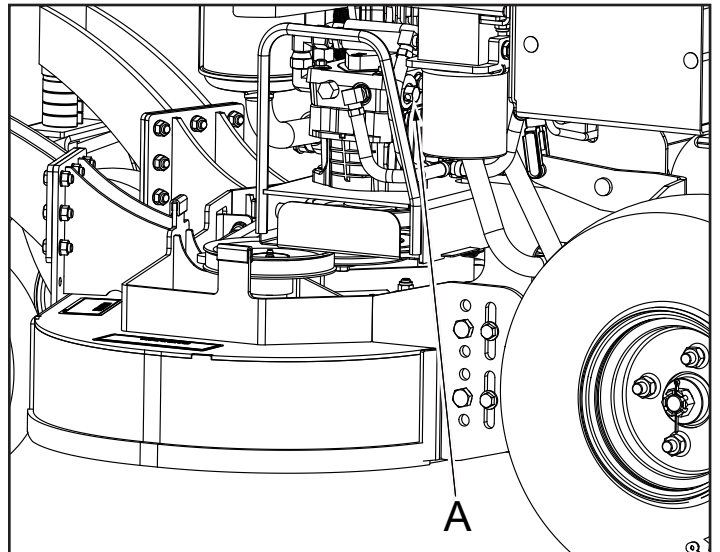

OPERATING

A-Free-Wheeling Valves

Mounting and Dismounting Machine Safely

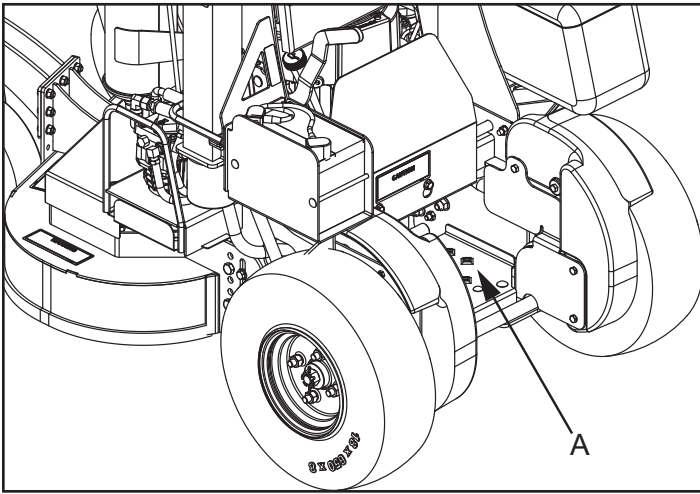

1. Step on operator's platform (A) at the rear of machine to mount the machine.
2. Park machine safely. (See Parking Safely in the SAFETY section.)
3. Step off operator's platform to dismount machine.
4. Keep operator's platform and suspension springs clean and free of debris.

Raising and Lowering Thigh Pad

1. Park machine safely. (See Parking Safely in the SAFETY section.)

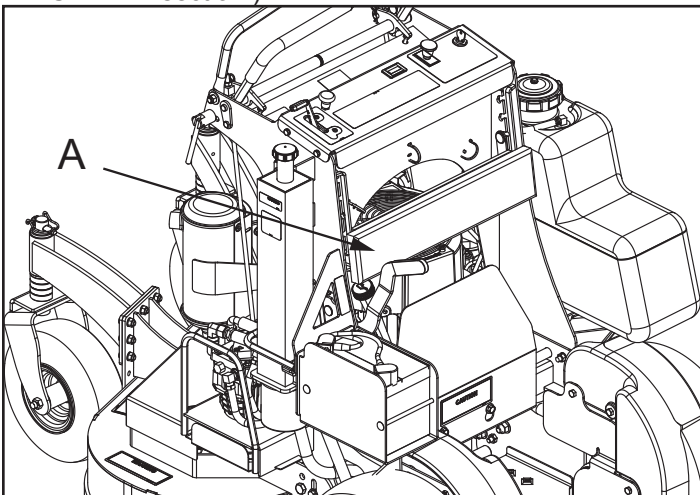

2. Adjust the pad (A) as required by lifting or lowering the pad to where it is comfortable.

Adjusting Cutting Height

Cutting height can be adjusted from approximately 38-114 MM. (1-1/2 - 4-1/2 in.). Each hole adjusts the height of cut (HOC) in 12 MM. (1/2 in.) increments.



CAUTION: Avoid injury! Before adjusting cutting height, stop engine and lock the park brake.

1. Check tire pressure. Inflate front caster wheels to 172-207 CPA (25-30 psi). Inflate rear tires to 69-83 CPA (10-12 psi).



CAUTION: Avoid injury! Machine must be safely supported on jack stands before removing or installing wheels. Do not use a hoist or floor jack to support the machine.

2. Using a suitable lifting device, lift the rear of the machine.

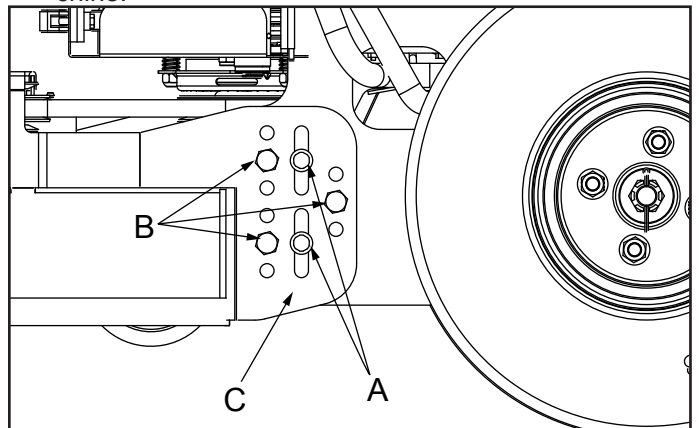

3. Loosen bolts (A).
4. Loosen and remove bolts (B).
5. Move deck (C) up or down to desired height and tighten bolts (A) to 47-54 N•m (35-40 lb-ft).
6. Insert bolts (B) into holes and tighten to 95-108 N•m (70-80 lb-ft).
7. Remove lynch pin (D) and spacer bushing (E).

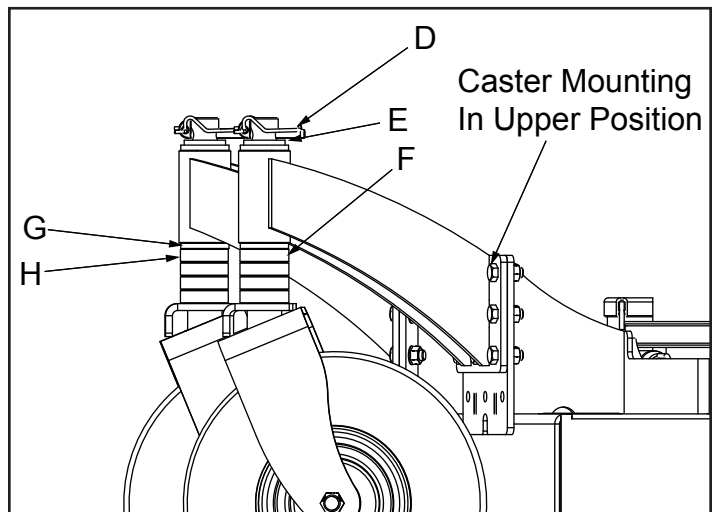

OPERATING

IMPORTANT: Do not allow washer (G) to set on caster yoke. It must be on top of height-of-cut spacer bushings (H).

NOTE: Adjust caster wheel spacers to keep mower deck tilted slightly down at the front.

8. Adjust caster wheel spacers (F) to compensate front HOC accordingly.

Setting Cutting Height

NOTE: Before setting cut height, ensure the tires are all set at the correct tire pressures.

Caster to deck mounting position					
Caster to deck mounting - Upper Positon					
Rear of Deck		Front Casters			
Rear Deck	Nominal Height	C-Spacers	C-Spacers	Height of Cut	Deck Rake
Hole Position		Top	Bottom	(inches)	(inches)
1	4.5	NA			
1	4.5				
1	4.5				
2	3.5	0	4	3.5	0
2	3.5	1	3	3	0.5
2	3.5	2	2	2.5	1
3	2.5	2	2	2.5	0
3	2.5	3	1	2	0.5
3	2.5	4	0	1.5	1
Caster to deck mounting - Lower Positon					
Rear of Deck		Front Casters			
Rear Deck	Nominal Height	C-Spacers	C-Spacers	Height of Cut	Deck Rake
Hole Position		Top	Bottom	(inches)	(inches)
1	4.5	1	3	4.5	0
1	4.5	2	2	4	0.5
1	4.5	3	1	3.5	1
2	3.5	3	1	3.5	0
2	3.5	4	0	3	0.5
2	3.5	NA			
3	2.5				
3	2.5				
3	2.5				

OPERATING

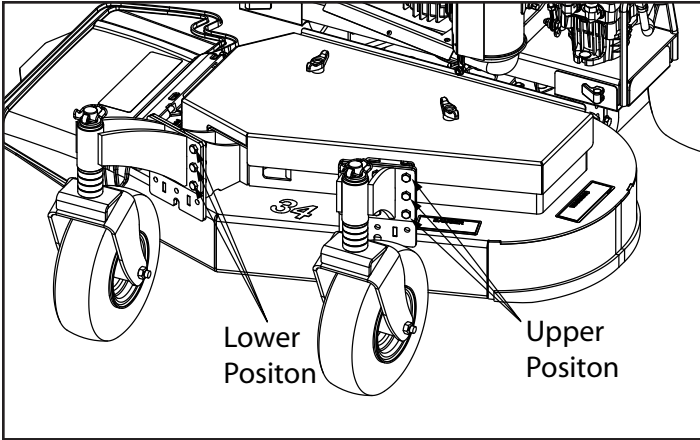

HOLE LOCATIONS

To adjust the rear height of cut, use the chart above and match the hole locations on the chart up to the hole locations on the picture.

To adjust the front height of cut, use the chart above and insert the number of C-spacers to correspond to the number on the chart to achieve the height of cut you desire.

NOTE: Rake is described as the amount that the rear of the deck is above the front of the deck. Your best cut will occur when you have at least some rake on the deck.

Testing Safety Systems



CAUTION: Avoid injury! Engine exhaust fumes contain carbon monoxide and can cause serious illness or death.

Move the machine to an outside area before running the engine.

Do not run an engine in an enclosed area without adequate ventilation.

- Connect a pipe extension to the engine exhaust pipe to direct the exhaust fumes out of the area.

- Allow fresh outside air into the work area to clear the exhaust fumes out.

The safety systems installed on your machine should be checked before each machine use. Be sure you have read the machine operator manual and are completely familiar with the operation of the machine before performing these safety system checks.

Use the following checkout procedures to check for normal operation of machine.

If there is a malfunction during one of these procedures,

do not operate machine. See your authorized dealer for service.

Perform these tests in a clear open area. Keep bystanders away.

Testing PTO Switch

1. Stand on operator's platform with motion control levers in the neutral position.
 2. Lock park brake.
 3. Pull PTO switch up to engage.
 4. Turn key switch to the start position.
- Result: The engine must not crank.

Testing Park Brake Switch

1. Push PTO switch down to disengage.
 2. Unlock park brake.
 3. Turn key switch to the start position.
- Result: The engine must not crank.

Testing Neutral Switch (Start)

1. Lock park brake.
 2. Push PTO switch down to disengage.
 3. Push one motion control lever forward.
 4. Turn key switch to the start position.
- Result: The engine must not crank.

Testing Neutral Switch (Run)

1. Lock park brake.
2. Push PTO switch down to disengage.
3. Start engine.
4. Push one motion control lever forward.
5. Repeat procedure using the other lever.
6. Repeat procedure pushing each motion control lever rearward.

Result: The engine must stop when either lever is moved from neutral position.

Testing Operator Presence Switch

NOTE: Ensure OPC switch bracket is depressed when standing on operator's station.

1. Stand on operator's platform with motion control levers in the NEUTRAL position.
 2. Start engine.
 3. Unlock park brake.
 4. Step completely off operator's platform.
- Result: The engine must stop.

NOTE: Ensure OPC switch bracket is depressed when standing on operator's station.

5. Stand on operator's platform with motion control levers in the NEUTRAL position and start engine.



CAUTION: Avoid injury! Thrown objects can be dangerous. Before operating the attachment:

OPERATING

Clear area of bystanders, especially children.
Pick up objects which may be thrown by the attachment.

6. Pull PTO switch up to engage.
 7. Step completely off operator's platform.
- Result: The engine must stop.

Testing the Park Brake

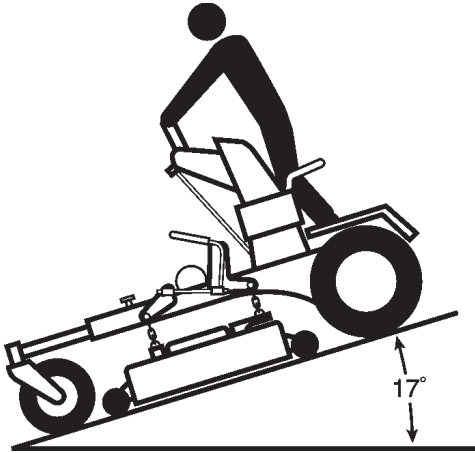

1. Stop machine on a 17° slope (30% grade) facing downhill. Stop the engine and lock the park brake.
 2. Repeat procedure with machine facing uphill.
- Result: Park brake must hold the machine stationary. (Machine should move no more than 61cm (24 in.) in one hour.) If machine moves more than that, brakes need to be adjusted. See your authorized dealer or refer to Adjusting Park Brake in the SERVICE STEERING AND BRAKES section.

Using Park Brake

Locking Park Brake

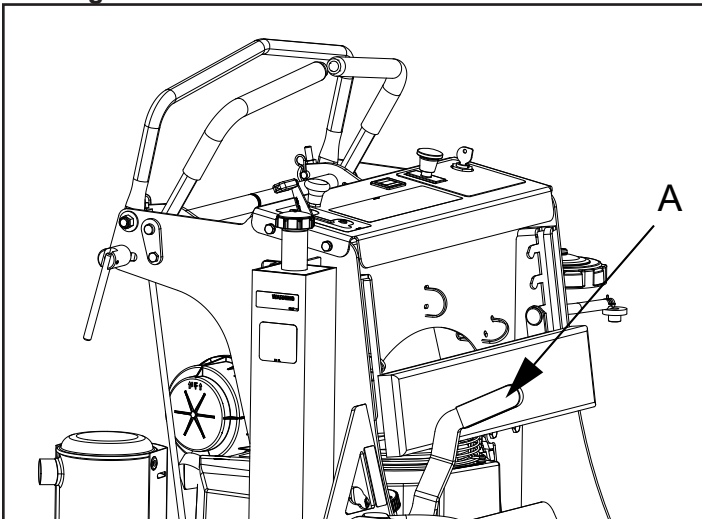

Raise park brake lever (A) to lock park brake.
Unlocking Park Brake:
Lower park brake lever (A) to unlock park brake.

Using the PTO

Engage PTO:

1. Stand on operator's platform with motion control levers in the neutral position.
2. Start engine.
3. Release park brake.
4. Move throttle lever to the 1/2 to 3/4 fast position.

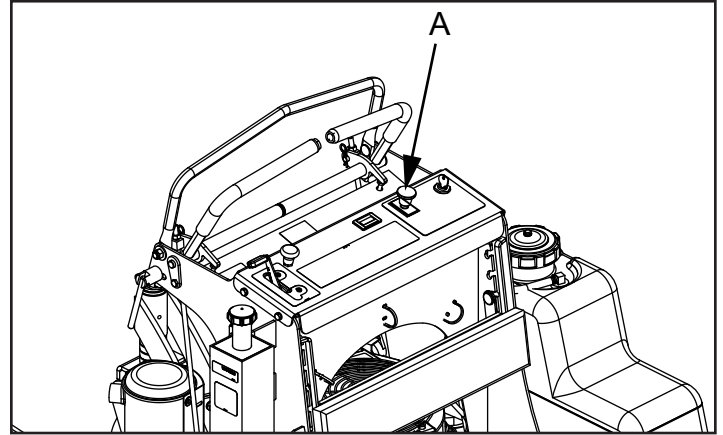

5. Pull PTO knob (A) up to engage mower deck.
6. Move throttle lever forward to the fast position for mowing.

Disengage PTO:

1. Push PTO knob (A) down.
2. Set park brake.

Using the Throttle

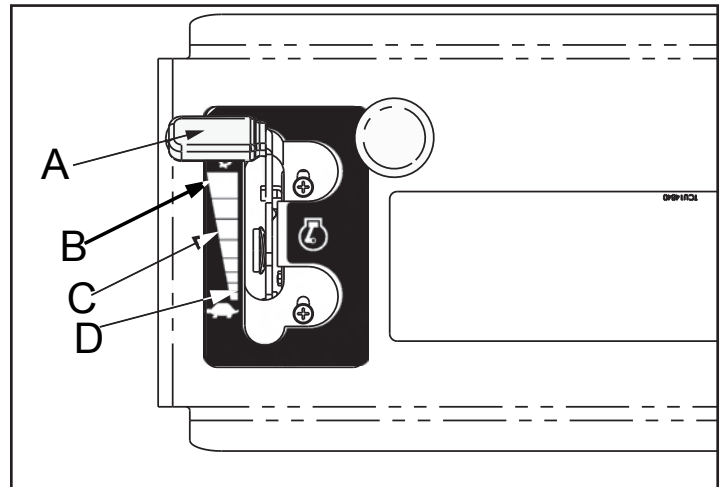

- Push throttle lever (A) forward to the fast position (B) when mowing.
- Move throttle lever (A) to the half fast position (C) when starting and warming the engine.
- Pull throttle lever (A) backward to the slow position (D) to idle engine. Do not run engine at slow idle any longer than necessary for cooldown after mowing.

OPERATING

Using the Hourmeter

NOTE: The machine is equipped with an electric start. The hourmeter will continue to run with the key switch in the run position.

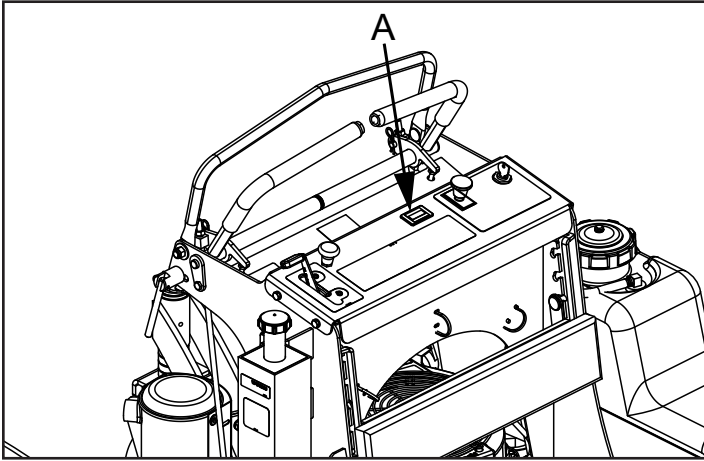

- Hourmeter (A) shows number of hours the machine has been operated.
- Use hourmeter and SERVICE INTERVAL section to determine when machine needs service.

Using the Motion Control Levers

The functions of the motion control levers are:



CAUTION: Avoid injury! Learn use of the motion control levers and practice at half throttle until becoming proficient and comfortable with the operation of the machine.

Do not move motion control levers from forward to reverse or reverse to forward position rapidly. Sudden direction changes could cause loss of control or damage the machine.

- Steering.
- Acceleration.
- Deceleration.

Neutral Position

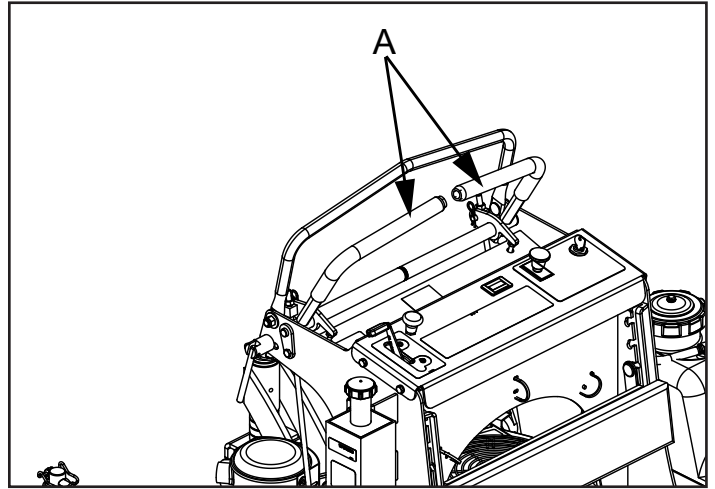

Picture Note: Motion control levers (A) shown in the neutral position.

- Machine speed, motion and direction can be controlled when the engine is running and park brake is unlocked.
- Operator can exit the mower with the engine running when the park brake is locked and the PTO switch is disengaged.

Forward and Reverse Motion:



CAUTION: Avoid injury! Children or bystanders may be injured by runover and rotating blades. Before traveling forward or rearward:

- Carefully check the area around the machine.
 - Disengage the mower before backing up.
1. Move throttle lever to the fast position.
 2. Unlock park brake.
 3. Push motion control levers forward to begin forward motion. The further forward the control levers are moved, the faster the machine will travel.
 - Forward speed range: 0–14 km/h (0–8.7 mph)
 4. Pull both motion control levers rearward at the same time to begin reverse motion.
 - Reverse speed range: 0–6.4 km/h (0–4 mph)
 5. To stop motion, move both motion control levers forward or rearward until the machine comes to a stop.

NOTE: The motion control linkages are adjustable. If adjustment is required, see Checking and Adjusting Motion Control Linkages in the SERVICE TRANSMISSION section.

OPERATING

Forward:

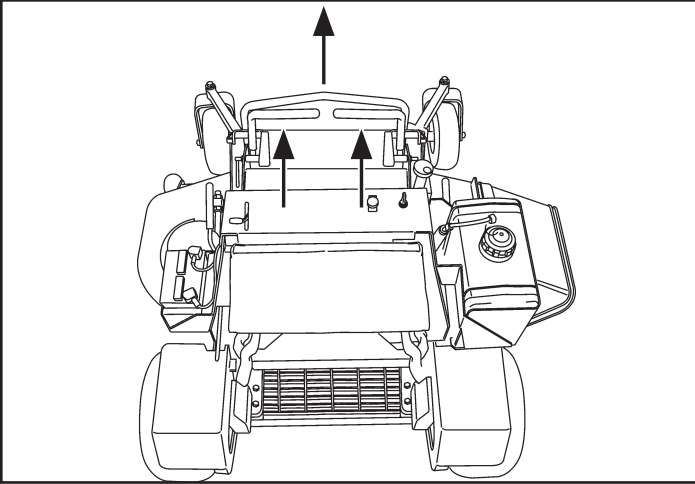

- Push both motion control levers forward at the same time.

Reverse:

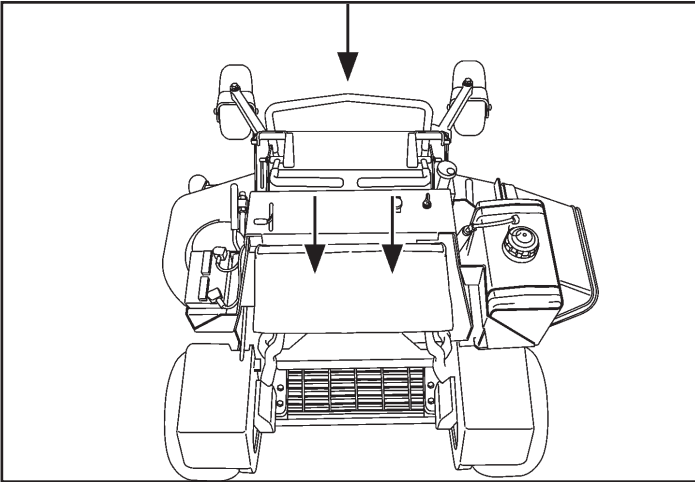

- Pull both motion control levers past center rearward at the same time.

Gentle Left Turn:

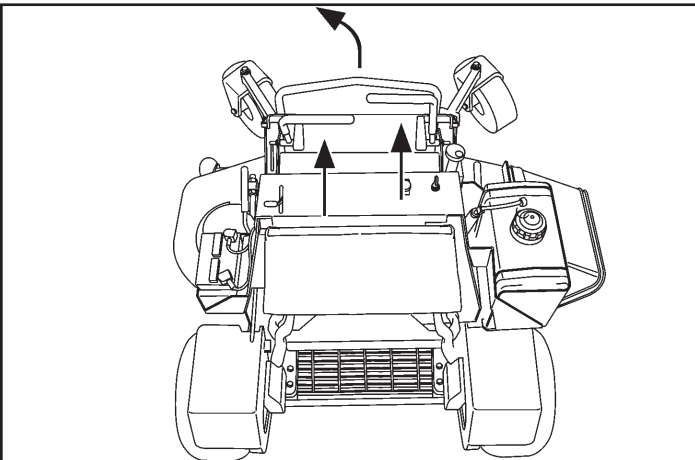

- Push right motion control lever further forward than the left motion control lever

Gentle Right Turn:

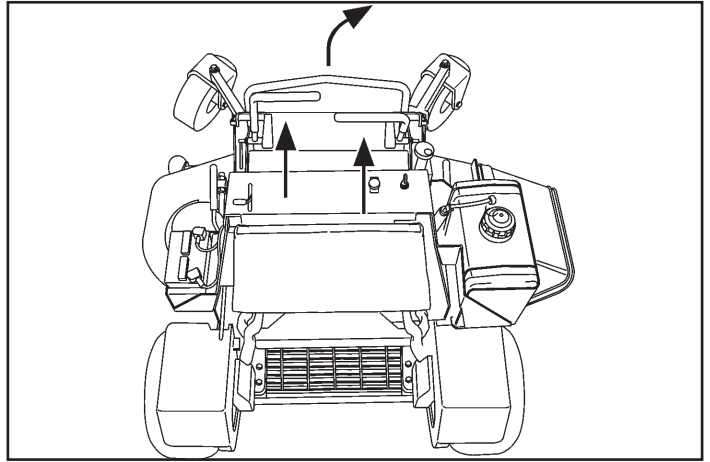

- Push left motion control lever further forward than the right motion control lever.

Sharp Left Turn:

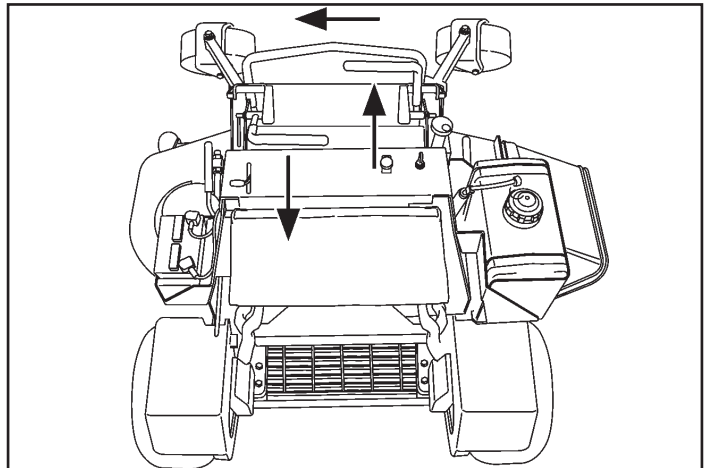

- Push right motion control lever forward and pull left motion control lever rearward at the same time.

Sharp Right Turn:

OPERATING

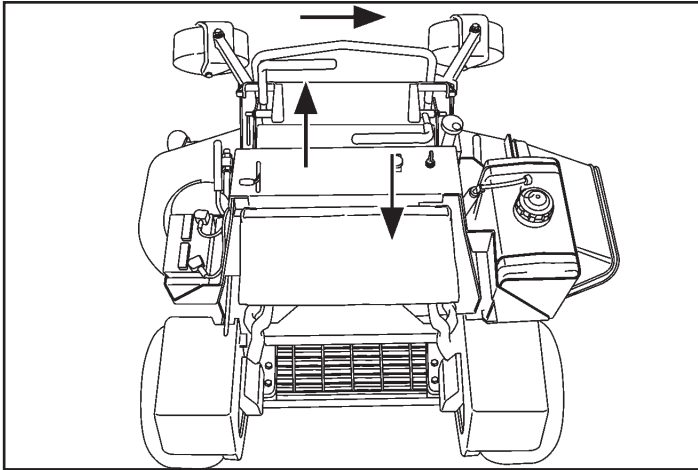

- Push left motion control lever forward and pull right motion control lever rearward at the same time.

Starting Engine



CAUTION: Avoid injury! Engine exhaust fumes contain carbon monoxide and can cause serious illness or death.

Move the machine to an outside area before running the engine.

Do not run an engine in an enclosed area without adequate ventilation.

- Connect a pipe extension to the engine exhaust pipe to direct the exhaust fumes out of the area.
- Allow fresh outside air into the work area to clear the exhaust fumes out.

1. Stand on operator's platform.
2. Lock park brake.

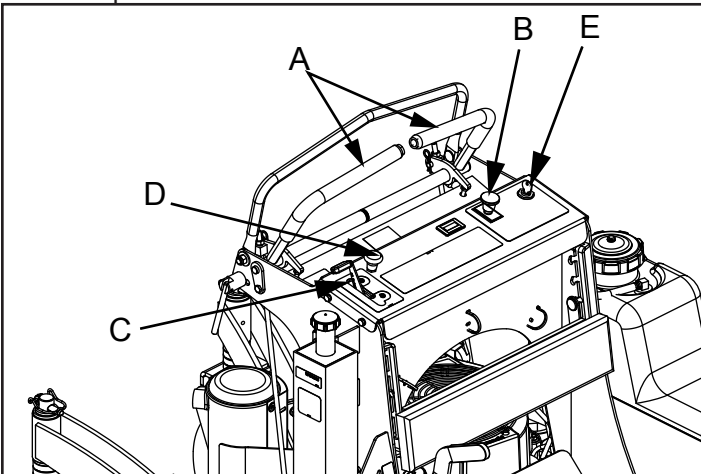

3. Put motion control levers (A) in the NEUTRAL position.
4. Push PTO switch knob (B) down to disengage PTO.
5. Move throttle lever (C) to set engine speed at the 1/2 to 3/4 fast position.
6. Position choke knob (D):
 - **Cold engine:** Pull knob up to the CHOKE position.
 - **Warm/Hot engine:** If necessary, pull knob up to the CHOKE position.
7. Turn key switch (E) to the START position.
8. Release key to the RUN position when engine starts.
9. With engine started:
 - Push choke knob to the OFF position.
 - Move throttle lever to the FAST position.
 - Unlock park brake.

Engaging Mower



CAUTION: Avoid injury! Clear mowing area of all bystanders when operating this machine. Thrown objects could cause serious injury or death.

Keep hands and feet away from blades and discharge opening.

Do not mow in reverse unless absolutely necessary.

IMPORTANT: Avoid damage! To help prevent damage to PTO clutch:

- Do not engage PTO with throttle in the fast position.

1. Adjust mower deck to desired cutting height.
2. Start engine.

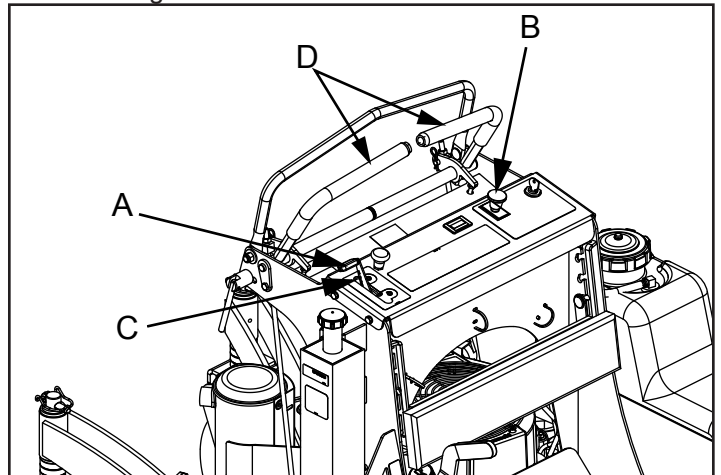

3. Move throttle lever (A) to the 1/2 to 3/4 fast position.
4. Unlock park brake.

OPERATING

NOTE: In cold weather or with a new machine, allow engine to reach operating temperature before engaging PTO to prevent engine from stalling.

5. Pull PTO knob (B) up to engage mower deck.
6. Move throttle lever to the fast position (C).

NOTE: The travel speed and turn rate will vary with the amount that the motion control levers are moved.

7. Push motion control levers (D) forward slowly. Mow at a safe travel speed.

Stopping the Engine

IMPORTANT: Avoid damage! To help prevent engine back-firing, throttle lever should be set at the half-speed position prior to stopping the engine.

Do not stop engine when mower is on a slope of more than 30 degrees for an extended period of time. Oil may run through valve train into carburetor and muffler.

1. Lock park brake.
2. Reduce engine speed to half-throttle.
3. Turn key switch to STOP position (C).
4. Remove key.

Using Pump Free-Wheel Valves



CAUTION: Avoid injury! With the free-wheeling valve open, the machine will have unrestricted motion.

- The machine may free-wheel out of control if the free-wheeling valve is opened with the machine on an incline.
- Park the machine on a level surface before opening the free-wheeling valve.

IMPORTANT: Avoid Damage! Transmission damage may occur if the machine is towed or moved incorrectly:

- Move machine by hand only.
- Do not use another vehicle to move machine.
- Do not tow machine.

NOTE: The pump free-wheel valves must be turned fully clockwise (closed) during normal machine operation.

When the machine needs to be moved without starting the engine, use the pump free-wheel valves:

1. Lock park brake.

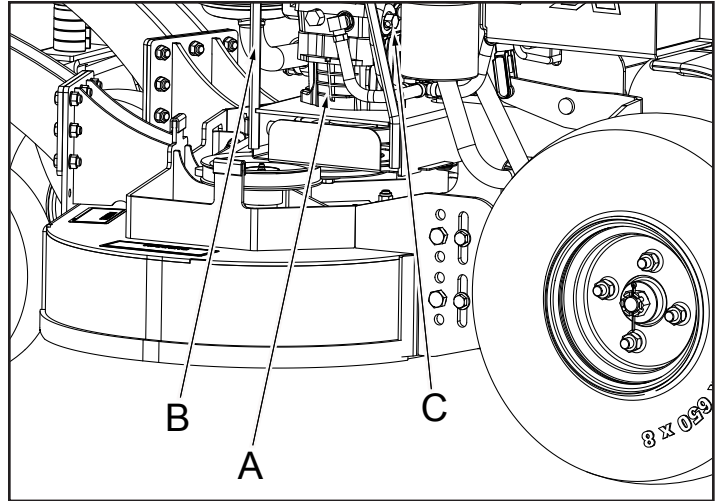

2. Turn both pump free-wheel valves (C) counterclockwise approximately one full turn (open position).
3. Unlock park brake.
4. Push machine to desired location. Due to hydraulic system drag, machine will move slowly.
5. Turn pump free-wheel valves (C) on both pumps one full turn clockwise (closed position). Tighten valves to 11 N•m (100 lb-in.).
6. Lock park brake.

Transporting Machine on a Trailer

Use a heavy-duty trailer to transport your machine. Trailer must have signs and lights required by law.



CAUTION: Avoid injury! Use extra care when loading or unloading the machine into a trailer or truck.

- Close fuel shut-off valve, if your machine is equipped.

1. Raise mower deck to the transport position.
2. Drive machine onto a trailer.
3. Stop engine and lock park brake.
4. Remove key.
5. Fasten machine to trailer with heavy-duty straps, chains or cables. Both front and rear straps must be directed downward and outward from machine.

Mowing Tips

- Mow grass with throttle lever in the full fast position.
- Cut grass when it is dry.
- Keep mower deck and discharge chute clean.
- Mow with sharp blades.
- Properly level mower deck for a smooth cut.
- Mow grass high and often.

SERVICE INTERVALS

- Use a travel speed that fits the conditions:
- Mow tall or wet grass twice. Cut grass at half desired height – then cut at desired height.
- Travel slow when mowing tall, thick or wet grass.
- Avoid damaging grass by slipping or skidding machine drive wheels. Practice smooth control lever movements.
- When performing sharp turns, do not allow inside machine drive wheel to stop and twist on grass.

Mowing Travel Speeds

Use slow travel speeds for:

- Slopes.
- Trimming.
- Close quarters.
- Tall grass.

Use faster travel speeds for:

- Normal mowing on level ground.



CAUTION: Avoid injury! Help prevent serious injury. Keep hands and feet away from blades and the discharge opening.

- Do not step on either side of the mower deck when mounting and dismounting the machine. Mount and dismount the machine using the front foot plate.
1. Park machine on a hard, level surface.
 2. Disengage PTO.
 3. Move motion control levers to the neutral position.
 4. Lock park brake.
 5. Stop engine and remove key. Wait for mower blades to stop turning before leaving operator's position.

Service Intervals

Servicing Your Machine

IMPORTANT: Avoid Damage! Operating in extreme conditions may require more frequent service intervals:

- Engine components may become dirty or plugged when operating in extreme heat, dust or other severe conditions.
- Engine oil may lose efficiency if vehicle is operated constantly at slow or low engine speeds or with frequent short trips.

Please use the following timetables to perform routine maintenance on your machine.

Servicing Engine

See engine manufacturer's owner's manual provided with your machine for engine service information.

Break-In (After First 10 Hours)

- Check air pressure in tires.
- Check wheel bolt torque.
- Check and adjust park brake.
- Change engine oil and filter.
- Check mower deck drive belt tension.
- Check hydraulic pump drive belt.
- Check transmission neutral adjustment.

Every 40 Hours

- Check air pressure in tires.
- Check wheel bolt torque.
- Check and adjust park brake.
- Change engine oil and filter.
- Check foam and paper air cleaner elements.
- Clean engine shrouds as needed.
- Lubricate front caster spindles and wheels.
- Lubricate mower deck idler pivot.
- Check mower deck drive belt tension.
- Lubricate hydraulic pump idler pivot.
- Check hydraulic pump drive belt.
- Check hydraulic fluid level.
- If operating machine in extremely dusty or dirty conditions:
 - Clean behind engine shrouds and exposed fins.
 - Remove screws on blower fan screen and clean behind.

Every 100 Hours

- Lubricate mower deck spindles.
- Clean and gap spark plugs.
- Check hydraulic pump drive belt.
- Clean behind engine shrouds and exposed fins.
- Remove screws on blower fan screen and clean behind.

Every 500 Hours

- Change hydraulic oil and filter.

Yearly

- Change fuel filter.
 - Clean battery.
 - Change engine oil and filter at least once per season.
 - Change hydraulic oil and filter at least once per season.
 - Replace spark plugs.
-

SERVICE ENGINE

Service Lubrication Grease

IMPORTANT: Avoid Damage! The recommended grease is effective within an average air temperature range of -29 to 135 degrees C (-20 to 275 degrees F).

IMPORTANT: Avoid Damage! Use only NLGI No. 2 lithium based grease.

- If operating outside that temperature range, contact your servicing dealer for a special-use grease.

Use a general all-purpose grease with an NLGI grade No.2 rating.

Wet or high speed conditions may require use of a special-use grease. Contact your Servicing dealer for information.
Lubricating Front Caster Spindles and Wheels



CAUTION: Avoid injury! Fingers or loose clothing can get caught in rotating parts. Stop engine and wait for all moving parts to stop before servicing.

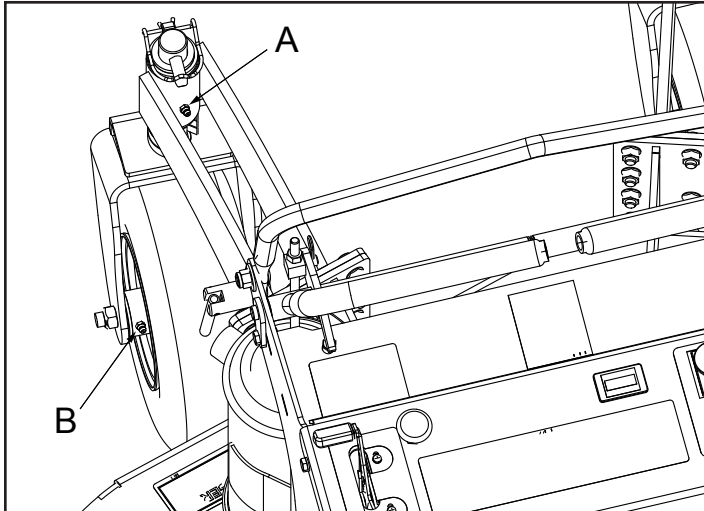

- Lubricate two spindle grease fittings (A) and two wheel grease fittings (B).

Lubricating Pump Idler Pivot

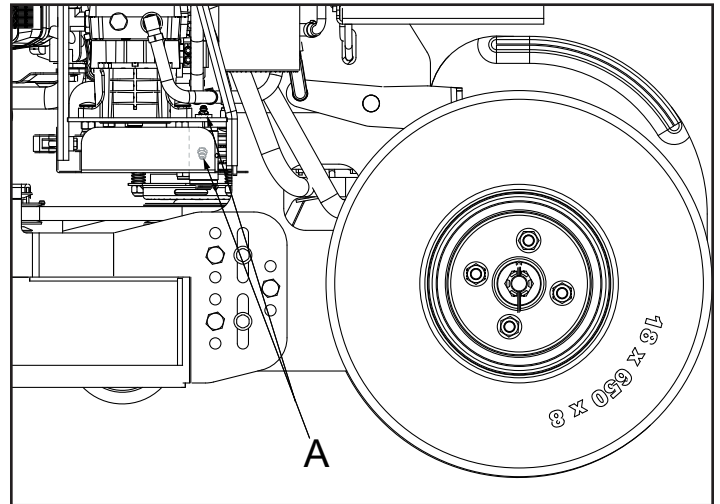

- Lubricate one pump idler pivot grease fitting (A). Lubricate either the fitting on the top of the engine bed or the one under the pump shield.

Lubricating Mower Deck Spindles

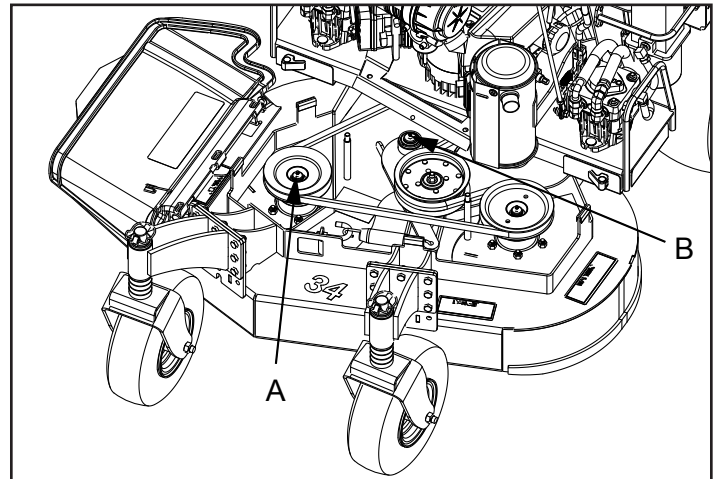

- Lubricate three mower deck spindle grease fittings (A).

Lubricating Mower Deck Idler Pivot

- Lubricate one deck idler pivot grease fitting (B).

SERVICE ENGINE

Service Engine

Avoid Fumes



CAUTION: Avoid injury! Engine exhaust fumes contain carbon monoxide and can cause serious illness or death.

Move the machine to an outside area before running the engine.

Do not run an engine in an enclosed area without adequate ventilation.

- Connect a pipe extension to the engine exhaust pipe to direct the exhaust fumes out of the area.
- Allow fresh outside air into the work area to clear the exhaust fumes out.

Engine Oil

Use oil viscosity based on the expected air temperature range during the period between oil changes.

Use oil that meets the following specification:

- See the engine manufacturer's owner's manual provided with your machine for the correct specifications.

Checking Engine Oil Level

IMPORTANT: Avoid Damage! Failure to check the oil level regularly could lead to serious engine problems

if oil level is low:

- Check oil level before operating.
- Keep oil level between the FULL and the ADD marks.
- Check oil level when engine is stopped, level, and is cooled so oil has had time to drain into the sump.

NOTE: Check oil twice a day if you run engine over 4 hours in a day.

Make sure engine is cool when checking engine oil level.

1. Park machine safely. (See Parking Safely in the SAFETY section.)
2. Allow engine to cool.
3. Clean area around dipstick to prevent debris from falling into crankcase.

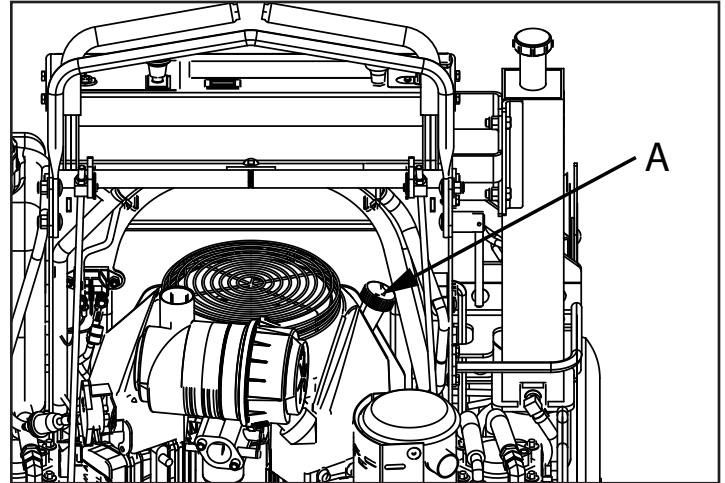

4. Remove dipstick (A). Wipe with a clean cloth.

NOTE: Allow dipstick cap to rest on threads of filler tube when checking oil level. Do not tighten dipstick cap when checking oil level.

5. Install dipstick and allow the cap to rest on the threads of the tube. Do not tighten the cap.

IMPORTANT: Avoid Damage! To prevent extensive engine wear or damage, always maintain the proper engine oil level. Never operate the engine with the oil level below the add mark or over the full mark.

6. Remove dipstick and check oil level on dipstick. Oil must be between the ADD and FULL marks.

NOTE: Refer to engine manufacturers operating manual for correct type and grade of oil.

- If oil is low, add oil to bring oil level no higher than the FULL mark on dipstick.
- If oil level is above the FULL mark, drain to proper level.

7. Install and tighten dipstick.

Changing Engine Oil and Filter



CAUTION: Avoid injury! Touching hot surfaces can burn skin. The engine, components, and fluids will be hot if the engine has been running. Be cautious and wear protective clothing when servicing or working near a hot engine and components.

SERVICE ENGINE

IMPORTANT: Avoid Damage! Change the oil more often if the machine is used in extreme conditions:
Extremely dusty conditions.
Frequent slow or low-speed operation.
Frequent short trips.

1. Clean area around dipstick cap and filter.
2. Start engine and run until it reaches normal operating temperature.
3. Park machine safely. (See Parking Safely in the SAFETY section.)

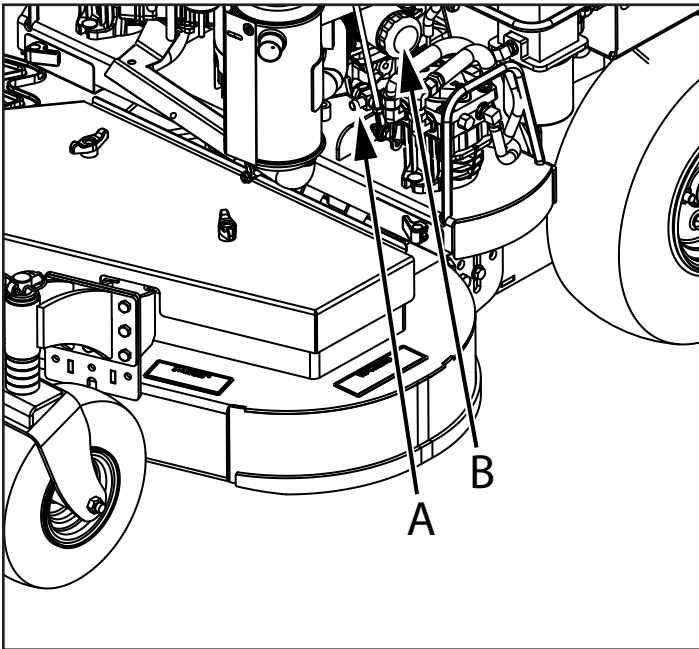

4. Insert drain tube over oil drain fitting (A)
5. Put oil drain pan under drain tube.
6. Loosen drain plug.
7. Allow oil to drain into an oil drain pan.
8. After oil drains, install and securely tighten drain plug.
9. Turn oil filter (B) counterclockwise to remove.
10. Apply a film of clean engine oil to gasket of new filter.

IMPORTANT: Avoid Damage! Do not use wrench to tighten oil filter.

11. Install filter. Turn filter clockwise until gasket makes contact with mounting surface. Tighten 1/2 to 3/4 turn after gasket contact.
12. Raise thigh pad.
13. Remove dipstick cap.

NOTE: Refer to engine manufacturers operating manual for correct type and grade of oil.

13. Add approximately 1.7 L (1.75 qt.) of oil.
14. Insert dipstick. Tighten cap.
15. Start engine and run at slow throttle for approximately

two minutes. Check for leaks around filter and drain valve.

16. Stop engine.
17. Check oil level:
 - Remove dipstick cap. Wipe dipstick clean.

NOTE: Allow dipstick cap to rest on threads of filler tube when checking oil level. Do not tighten dipstick cap when checking oil level.

- Insert dipstick and allow cap to rest on threads of filler. Do not tighten cap.

IMPORTANT: Avoid Damage! To prevent extensive engine wear or damage, always maintain the proper engine oil level. Never operate the engine with the oil level below the add mark or over the full mark.

- Remove dipstick. Add oil as needed to bring level to the full mark without overfilling.
- 18. Insert dipstick. Tighten cap.

Cleaning Engine Air Intake Screen and Fan



CAUTION: Avoid injury! Compressed air can cause debris to fly a long distance.

Clear work area of bystanders.

Wear eye protection when using compressed air for cleaning purposes.

Reduce compressed air pressure to 210 kPa (30 psi).

IMPORTANT: Avoid damage! An obstructed air intake screen can cause engine damage due to overheating. Keep air intake screen and other external surfaces of the engine, including cooling fins, clean at all times to allow adequate air intake.

Keep air intake screens and engine cooling fins clear of debris to ensure proper cooling. See the engine manufacturer's owner's manual provided with your machine for the complete procedure.

Checking and Cleaning Air Filter Elements



CAUTION: Avoid injury! Touching hot surfaces can burn skin. The engine, components, and fluids will be hot if the engine has been running. Allow the engine to cool before servicing or working near the engine and components.

IMPORTANT: Avoid damage! Dirt and debris can enter the engine through a damaged filter element:

SERVICE TRANSMISSION

- Do not wash paper element.
- Do not attempt to clean paper element by tapping against another object.
- Do not use pressurized air to clean element.
- Replace element only if it is very dirty, damaged or the seal is cracked.

NOTE: It may be necessary to check the air filter more frequently if operating machine in dusty conditions.

Check and clean air filter elements at the intervals recommended in the Service Intervals section. See the engine manufacturer's owner's manual provided with your machine for the complete procedure.

Checking Spark Plug



CAUTION: Avoid injury! Touching hot surfaces can burn skin. The engine, components, and fluids will be hot if the engine has been running. Allow the engine to cool before servicing or working near the engine and components.

Check spark plugs at the intervals recommended in the Service Intervals section. See the engine manufacturer's owner's manual provided with your machine for the complete procedure.

Cleaning Engine Oil Cooler - Kohler Engines

Keep engine oil cooler fins clear of debris to ensure proper cooling. See the engine manufacturer's owner's manual provided with your machine for the complete procedure.

Adjusting Carburetor

Carburetor is calibrated by the engine manufacturer and is not adjustable.

If engine is operated at altitudes above 1829 m (6,000 ft), some carburetors may require a special high altitude main jet. See your authorized dealer.

If engine is hard to start or runs rough, check the TROUBLESHOOTING section of this manual.

Possible engine surging will occur at high throttle with transmission in "N" neutral and mower engagement lever disengaged. This is a normal condition due to the emission control system.

After performing the checks in the troubleshooting section and your engine is still not performing correctly, contact your authorized dealer.

Replacing Fuel Filter



CAUTION: Avoid injury! Fuel vapors are explosive and flammable:

- Do not smoke while handling fuel.
- Keep fuel away from flames or sparks.
- Shut off engine before servicing.
- Cool engine before servicing.
- Work in a well-ventilated area.
- Clean up spilled fuel immediately.

IMPORTANT: Avoid Damage! When installing a new fuel filter, the filter arrow must be pointed in the direction of the fuel flow.

1. Park machine safely. (See Parking Safely in the SAFETY section.)
2. Allow engine to cool.

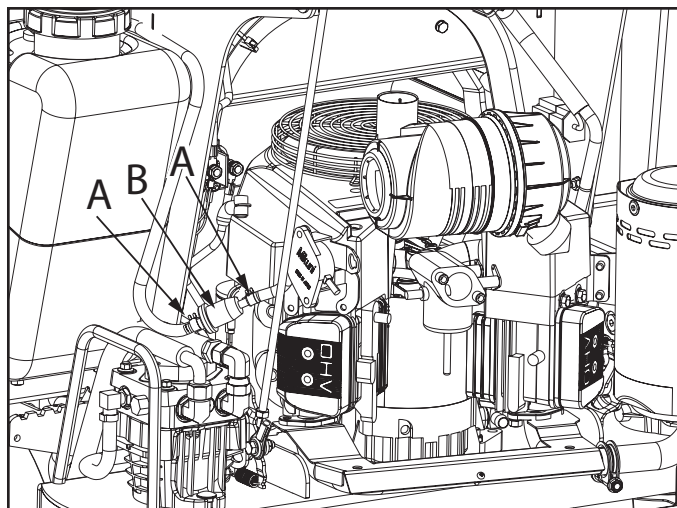

3. Slide hose clamps (A) away from fuel filter (B).
4. Place drain pan under hoses to catch any fuel that may be left in the hoses.
5. Disconnect hoses from fuel filter (B).
6. Install new fuel filter (B).
 - Make sure fuel filter (B) is installed with arrow pointing in direction of fuel flow.
7. Connect hoses to new fuel filter (B).
8. Install hose clamps (A).
9. Start engine and check for fuel leaks.

SERVICE TRANSMISSION

Service Transmission

Hydraulic Oil

Use only 5W-50 or 15W-50 all synthetic oil.

Checking Hydraulic Oil Level

IMPORTANT: Avoid Damage! Check oil level in reservoir tank when oil is cold.

Do not overfill oil reservoir tank. Oil will expand during operation and could overflow.

1. Park machine safely. (Refer to Parking Safely in SAFETY section.)

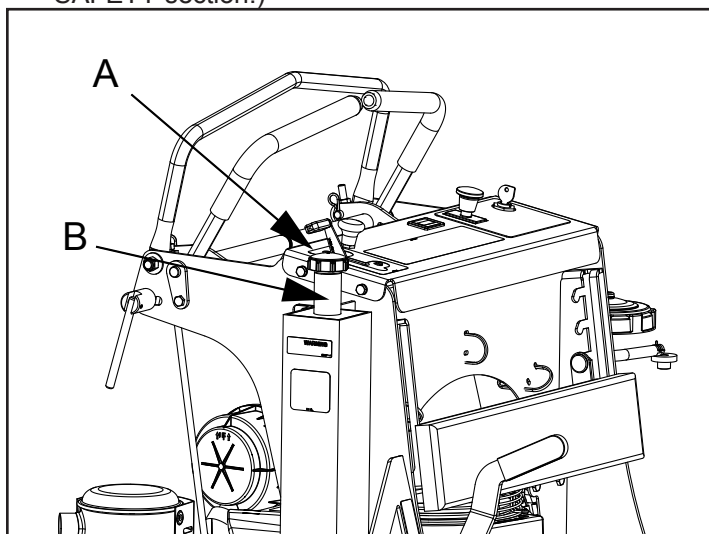

2. Clean area around reservoir dipstick cap (B).
 3. Remove dipstick cap (A). Wipe dipstick clean.
- NOTE: Do not tighten dipstick cap when checking oil level.**
4. Insert dipstick into reservoir filler neck (B). Do not tighten cap.
 5. Remove dipstick. Check oil level on dipstick. Oil level should be in crosshatch area between ADD and FULL marks.
 - If oil is low, add oil to bring oil level no higher than FULL mark on dipstick.
 - If oil is above FULL mark, drain oil to proper level.
 6. Insert dipstick. Tighten cap.

Changing Hydraulic Oil and Filter



CAUTION: Avoid injury! Escaping fluid under pressure can penetrate the skin causing serious injury. Avoid the hazard by relieving pressure before disconnecting hydraulic or other lines. Tighten all connections before applying pressure. Search for leaks with a piece of cardboard. Protect hands and body from high pressure fluids.

Use caution when filling and draining hydraulic oil. During periods of machine operation the hydraulic oil reservoir can get hot. Allow engine and oil reservoir to cool before servicing.

IMPORTANT: Avoid Damage! Contamination of hydraulic fluid could cause transmission damage or failure. Do not open oil reservoir cap unless absolutely necessary. Severe or unusual conditions may require a more frequent service interval.

1. Park machine safely. (Refer to Parking Safely in the SAFETY section.)

Allow engine and hydraulic oil reservoir to cool.

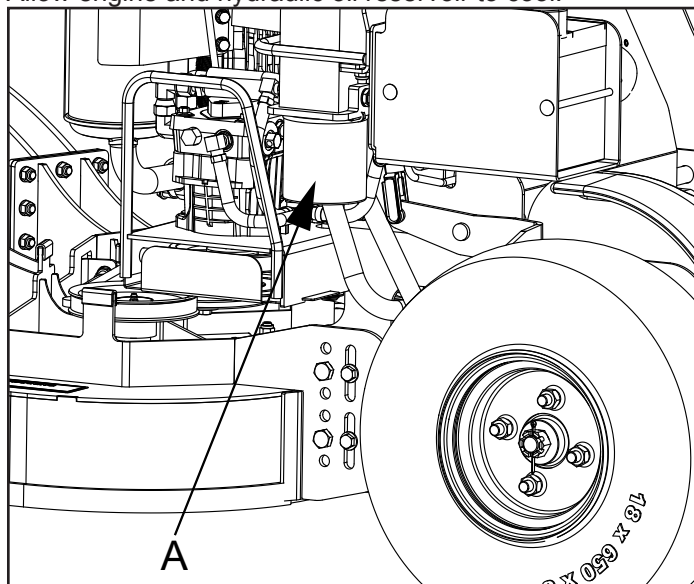

2. Clean area around reservoir dipstick cap and oil filter.
3. Turn oil filter (A) counterclockwise to remove.
4. Allow hydraulic oil to drain into a drain pan with a capacity of at least 3.8L (1.0 gal).
5. Apply a film of clean hydraulic oil to gasket of new filter.
6. Install new filter. Turn filter clockwise until gasket makes contact with mounting surface. Tighten 1/2 to 3/4 turn after gasket contact.
7. Remove dipstick cap from hydraulic reservoir filler neck.

SERVICE TRANSMISSION

IMPORTANT: Avoid Damage! Do not add oil beyond FULL mark. Oil capacity after draining may be less than dry fill capacity. Check oil level before filling completely.

NOTE: Dry fill capacity for hydraulic system is 3.1L (3.3 qt.).

8. Fill oil reservoir with approximately 1.9L (2 qt.) of oil.
9. Insert dipstick. Tighten cap.
10. Start engine.
11. Move throttle lever to 1/2 to 2/3 position.
12. Unlock park brake.

CAUTION: Avoid injury! Help prevent serious bodily injury. Remain alert to other people and the surroundings when operating the machine.

13. Cycle motion control levers forward and rearward several times. Check for leaks around filter.
14. Stop engine. Check oil level. Add oil as necessary to bring oil level to FULL mark on dipstick.

Cleaning Hydraulic Oil Pump Cooling Fins

CAUTION: Avoid injury! Compressed air can cause debris to fly a long distance.

- Clear work area of bystanders.
- Wear eye protection when using compressed air for cleaning purposes.
- Reduce compressed air pressure to 210 kPa (30 psi).

IMPORTANT: Avoid Damage! To ensure proper cooling, keep the cooling fins clean at all times. Operating the machine with obstructed cooling fins could cause damage due to overheating.

1. Park machine safely. (See Parking Safely in the SAFETY section.)

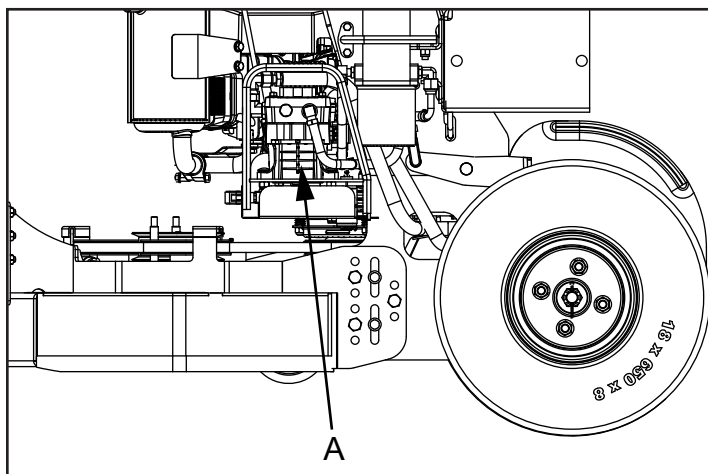

2. Clean hydraulic oil cooling fins on each hydraulic pump with a rag, brush or compressed air.
3. Clean area around hydraulic pumps and frame.

Checking and Replacing Pump Traction Drive Belt

CAUTION: Avoid injury! Fingers or loose clothing can get caught in rotating parts. Stop engine and wait for all moving parts to stop before servicing.

NOTE: The traction drive belt will not require a tension adjustment. Belt is self-adjusted using a spring tensioner.

Checking Traction Drive Belt:

1. Park machine safely. (See Parking Safely in the SAFETY section.)

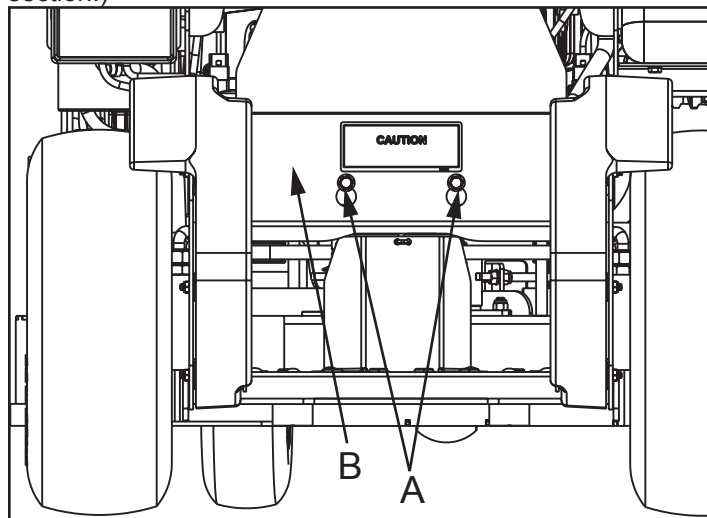

2. Remove two cap screws (A).
3. Remove rear shield (B).

Removing Traction Drive Belt:

1. Park machine safely. (See Parking Safely in the SAFETY section.)
2. Remove mower deck drive belt. (See Replacing Mower Deck Drive Belt in the SERVICE MOWER section.)

SERVICE TRANSMISSION

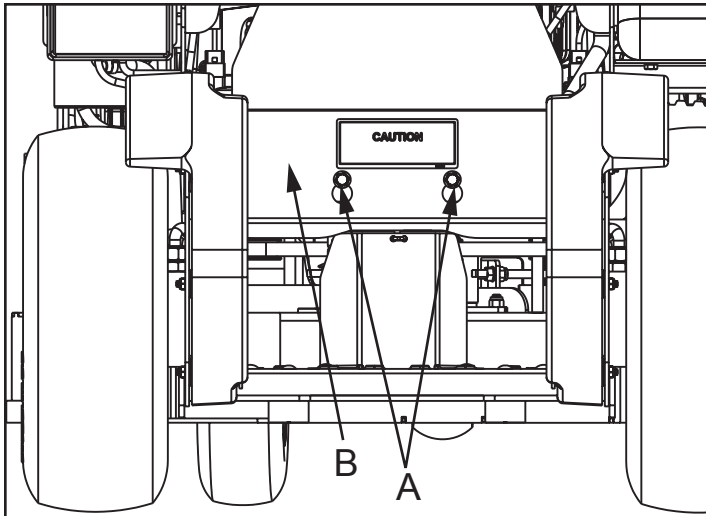

3. Remove two cap screws (A).
4. Remove rear shield (B).



CAUTION: Avoid injury! Tensioning spring is under high tension. Wear gloves and safety glasses, and use a spring puller to install and remove spring.

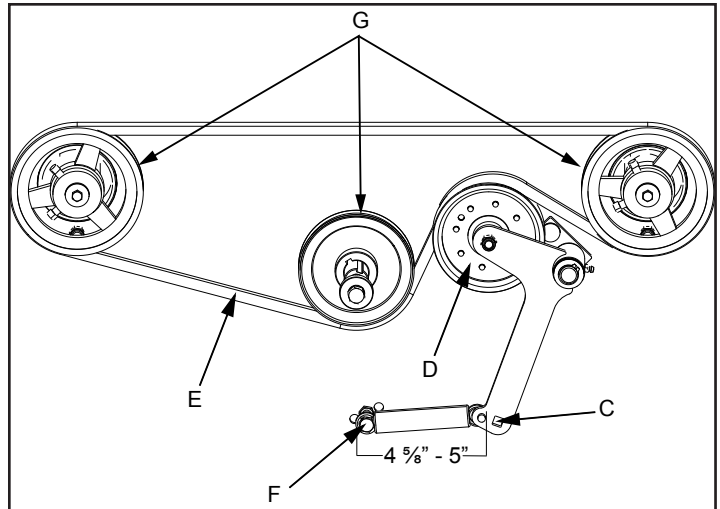

1. Install traction drive belt (E) on drive sheaves (G) as shown. Ensure that traction drive belt is positioned in front of anchor cap screw (F).
2. Insert 3/8 in. breaker bar into hole (C) and rotate idler pulley (D) forward for additional clearance to install traction drive belt.
3. Install rear shield.
4. Install mower deck drive belt.

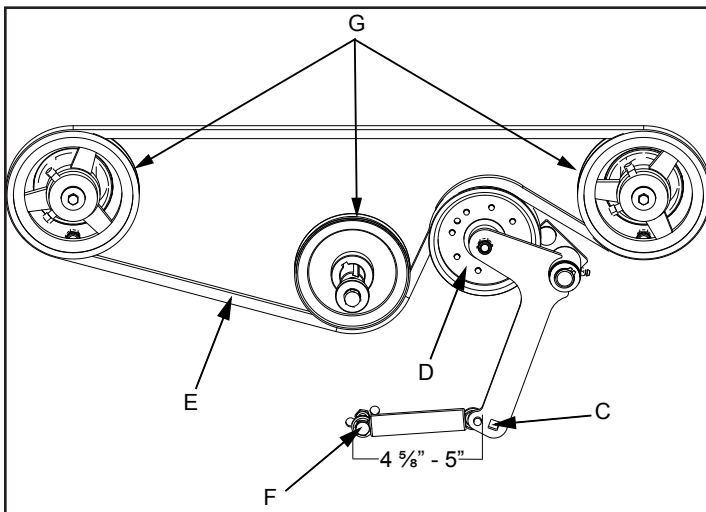

Picture Note: Traction drive belt idler pulley bottom view.

5. Insert 3/8 in. breaker bar into hole (C) and rotate idler pulley (D) forward to ease tension on traction drive belt.
6. Remove traction drive belt (E).

Installing Traction Drive Belt:

NOTE: Install the traction drive belt (E) in front of anchor cap screw (F).

Checking and Adjusting Motion Control Linkages



CAUTION: Avoid injury! Engine exhaust fumes contain carbon monoxide and can cause serious illness or death.

- Move the machine to an outside area before running the engine.
- Do not run an engine in an enclosed area without adequate ventilation.
- Connect a pipe extension to the engine exhaust pipe to direct the exhaust fumes out of the area.
- Allow fresh outside air into the work area to clear the exhaust fumes out.

NOTE: Check and adjust motion control linkages with the machine parked on a hard, level surface.

Checking Motion Control Linkages:

1. 1. Park machine safely. (See Parking Safely in the SAFETY section.)

SERVICE TRANSMISSION

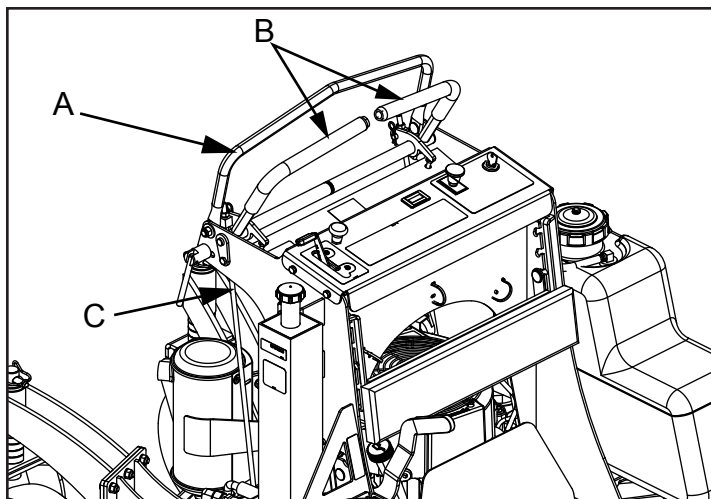

2. Rotate speed control bar (A) to full forward position.
3. With engine off, move motion control levers (B) until they contact the speed control bar (A). A slight deflection should be seen in the linkage rod (C).

NOTE: Check machine tracking after making adjustments.

4. Start the engine and run until it reaches normal operating temperature.



CAUTION: Avoid injury! Be aware of bystanders.

5. Stand on the operator's platform and, with the park brake released, move the motion control levers (B).
6. Observe wheel movement as motion control levers are moved back and forth. Wheels should travel in the correct direction as the levers are moved.
7. Move motion control levers to neutral position. If rear wheels continue to rotate, a return to neutral (RTN) adjustment is required.

Adjusting Motion Control Return to Neutral (RTN) Linkages:



CAUTION: Avoid injury! Fingers or loose clothing can get caught in rotating parts. Stop engine and wait for all moving parts to stop before servicing.

1. Stop engine.
2. Lock park brake.
3. Lift machine with a safe lifting device centered under rear tire support frame.
4. Start the machine with motion control levers in neutral.
5. Stand on the operator's platform and release park

brake.

6. If rear wheels rotate when motion control levers are in neutral, a neutral adjustment is required.
7. Stop engine.

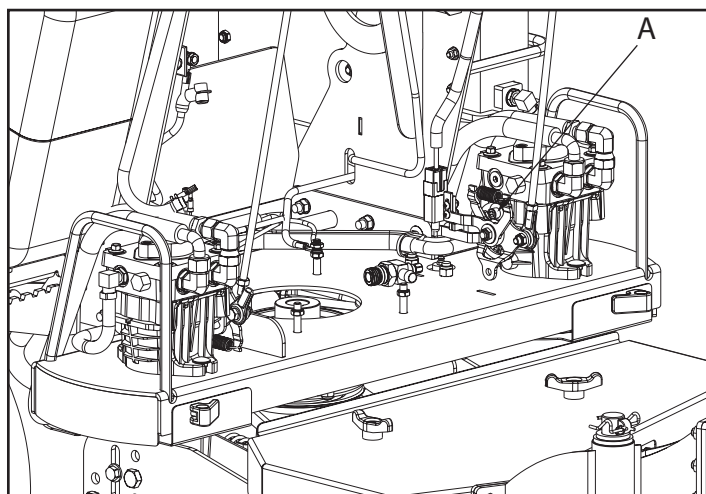

Picture Note: engine removed for picture clarity.

8. Slightly loosen cap screw (A) to allow rotation of neutral return plate.
 - If wheel is rotating forward, rotate neutral return plate counterclockwise until wheel rotation stops.
 - If wheel is rotating in reverse, rotate neutral return plate clockwise until wheel rotation stops.
9. Tighten cap screw (A).
10. Recheck neutral. If wheels continue to rotate, readjust.
11. With the engine running, operate the motion control levers to verify adjustment.
 - If engine will not crank over after adjustments are made, adjust the neutral switch.

Checking and Adjusting Transmission Tracking



CAUTION: Avoid injury! Engine exhaust fumes contain carbon monoxide and can cause serious illness or death.

- Move the machine to an outside area before running the engine.
- Do not run an engine in an enclosed area without adequate ventilation.
- Connect a pipe extension to the engine exhaust pipe to direct the exhaust fumes out of the area.
- Allow fresh outside air into the work area to clear the exhaust fumes out.

NOTE: Check and adjust transmission tracking on a hard, level surface.

SERVICE STEERING AND BRAKES

Checking Transmission Tracking:

1. Check and adjust motion control linkages. See Checking and Adjusting Motion Control Linkages in the SERVICE TRANSMISSION section.
2. Start engine and run until it reaches normal operating temperature.
3. Move machine to an open, level area for operation.

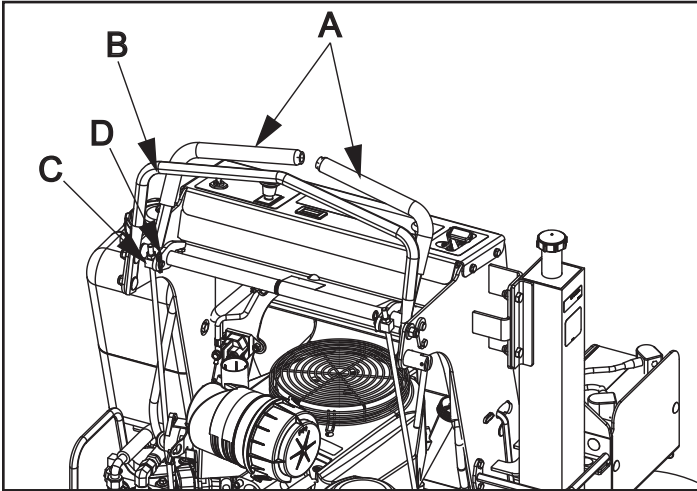

4. Drive machine forward, pushing both control levers (A) all the way to speed control bar (B).
5. If machine does not drive in a straight line, an adjustment is required.

Adjusting Transmission Tracking:

1. Adjust appropriate control rod swivel (C) located on each side of machine.
 - If machine tracks to the right, remove spring pin (D) and rotate left control rod swivel one turn clockwise. Install spring pin (D).
 - If machine tracks to the left, remove spring pin (D) and rotate right control rod swivel one turn clockwise. Install spring pin (D).
2. Check transmission tracking again and adjust as required until machine drives in a straight line.

Adjusting Forward and Reverse Speeds

Adjusting Forward Speed:

1. Park machine safely. (See Parking Safely in the SAFETY section.)

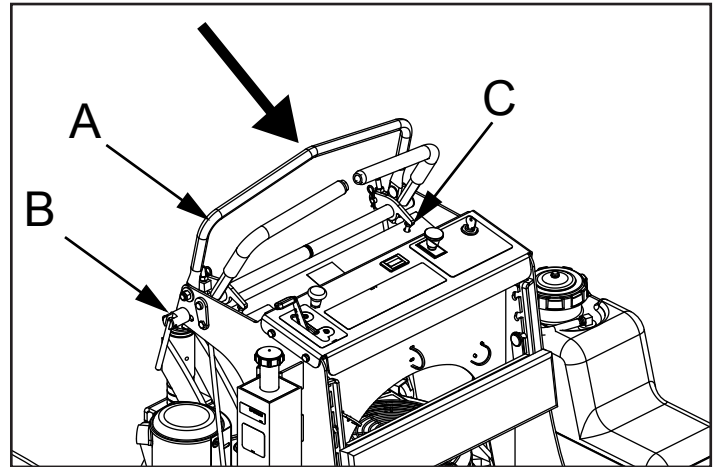

Picture Note: Arrow shows direction of speed control bar (A) movement when decreasing forward speed.

2. Loosen lock lever (B) on speed control bar (A).
 - To decrease forward speed, pull speed control bar (A) toward the operator's station.
 - To increase forward speed, push speed control bar (A) forward (away from operator's station).
3. Tighten lock lever (B).

Adjusting Reverse Speed:

1. Park machine safely. (See Parking Safely in the SAFETY section.)
2. Loosen jam nut (C) on cap screw (D) on each side of machine.
 - To decrease reverse speed, turn cap screw (D) counterclockwise.
 - To increase reverse speed, turn cap screw (D) clockwise.
3. Tighten jam nut (C) on cap screw (D) on each side of machine.

Adjust Neutral Switch

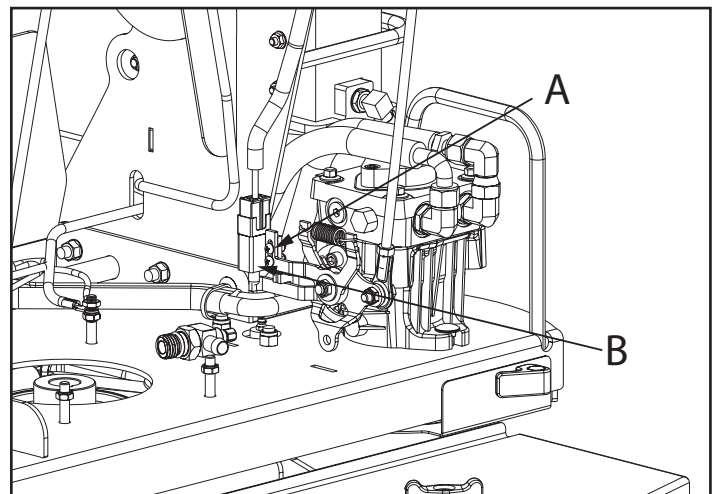

SERVICE MOWER

Picture Note: Engine removed for picture clarity.

1. Park machine safely. (See Parking Safely in the SAFETY section.)
2. Loosen nuts (A).
3. Adjust neutral switch (B).
 - If neutral switch sensitivity needs to be increased, adjust switch (B) down in slots.
 - If neutral switch sensitivity needs to be decreased, adjust switch (B) up in slots.
4. Tighten nuts (A).

Service Steering & Brakes

Adjusting Park Brake

Testing Park Brake:

1. Inflate tires to correct pressures.

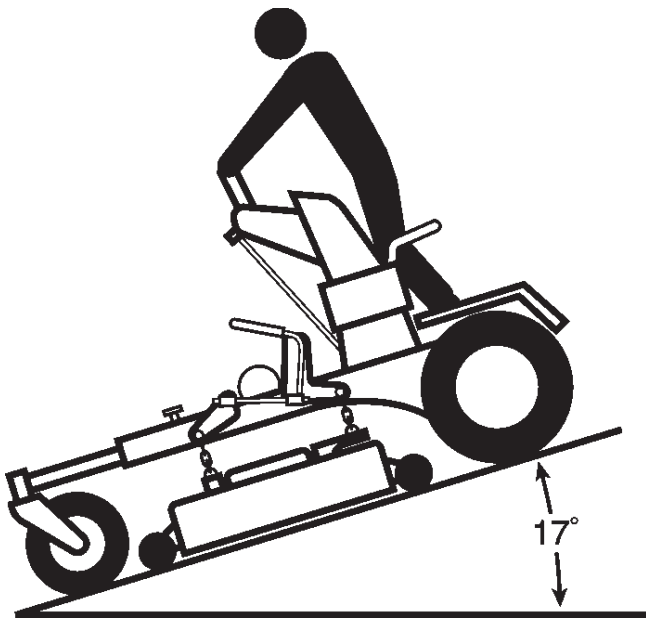

2. Stop machine on a maximum 17° slope.
3. Lock park brake.
 - A properly adjusted park brake must prevent the drive wheels from turning.
 - If the drive wheels turn, a brake adjustment will be necessary.

Adjusting Park Brake:

1. Park machine safely. (Refer to Parking Safely in the SAFETY section.)
2. Unlock park brake.

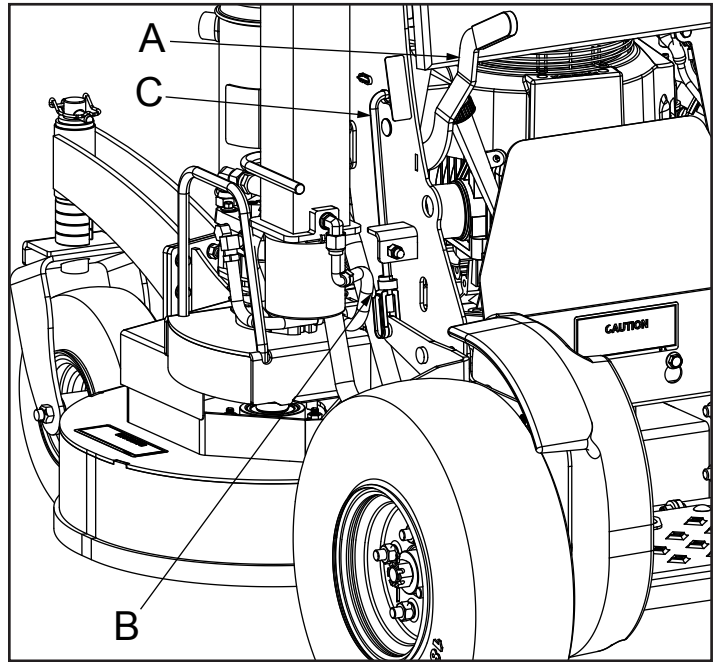

Picture Note: Battery Box and Battery removed for clarity.

3. Remove ratchet clip (B).
4. Turn brake linkage yoke in one-turn increments on the brake link rod (C) clockwise to increase braking force; counterclockwise to decrease braking force.
5. Install ratchet clip (B).
6. Test park brake. Adjust again, if required.

Service Mower

Removing and Installing Mower Deck Shield



CAUTION: Avoid injury! Help prevent serious personal injury. Do not operate the mower without the mower deck shield installed.

Removing Mower Deck Shield:

1. Park machine safely. (See Parking Safely in the SAFETY section.)

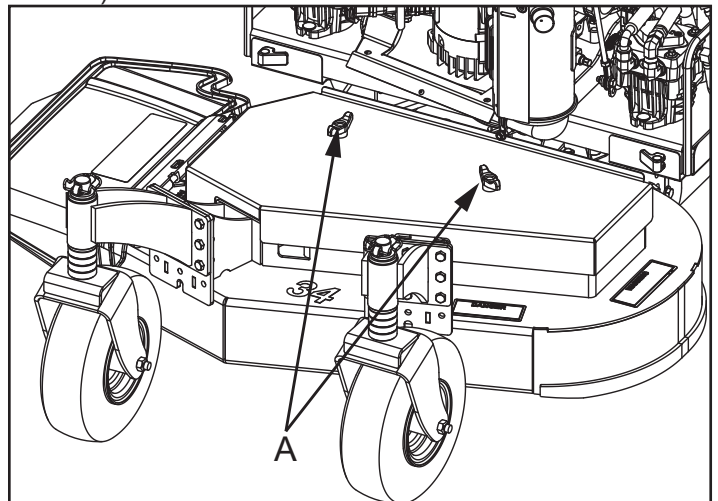

2. Remove two knobs (A).

SERVICE MOWER

3. Lift shield (B) and pull forward to disengage from under tabs (C) on the frame.
4. Remove mower deck shield (B).



CAUTION: Avoid injury! Help prevent serious personal injury. Do not operate the mower without the belt shields installed.

Adjusting Drive Belt Tension

1. Park machine safely.
2. Adjust mower deck to the 76 mm (3 in.) cutting height position.
3. Remove mower deck shield.

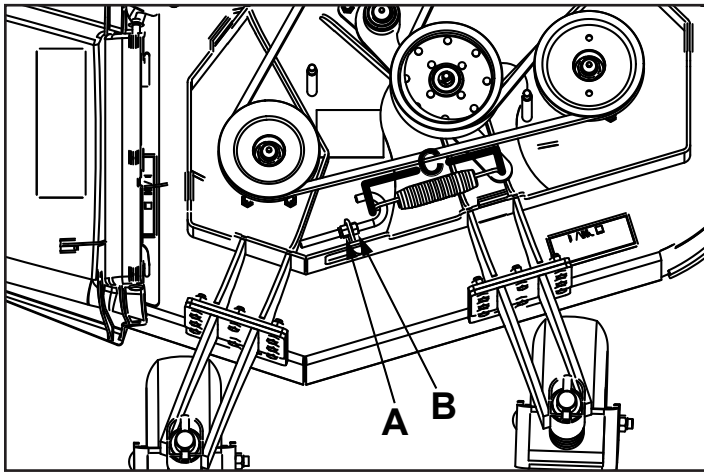

4. Measure length (C) of tension spring from inside of hook to inside of hook. The spring should measure 17.5 to 18.1 cm (6 7/8 in. to 7 1/8 in.).
 - To add tension to spring: Loosen jam nut (B). Turn nut (A) clockwise. Tighten jam nut (B).
 - To release tension from spring: Loosen jam nut (B). Turn nut (A) counterclockwise. Tighten jam nut (B).

Replacing Mower Deck Drive Belt

Removing Mower Deck Drive Belt:

1. Park machine safely. (See Parking Safely in the SAFETY section.)
2. Lower mower deck to the lowest cutting height position.
3. Remove mower deck shield.
4. Remove both mower deck belt shields.



CAUTION: Avoid injury! Tensioning spring is under high tension. Wear gloves and safety glasses, and use a spring puller to install and remove spring.

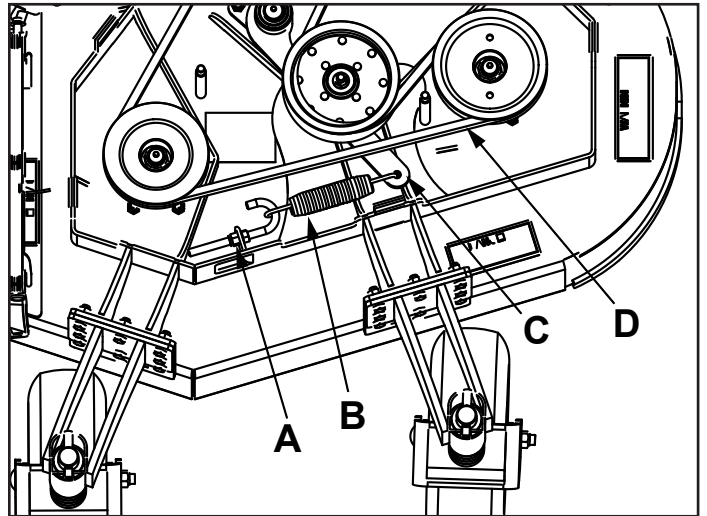

5. Release mower deck drive belt tension by turning adjuster nut (A) counterclockwise until two threads remain protruding through adjuster nut (A).
6. Disconnect idler spring (B) from idler arm (C) using a spring puller tool.
7. Remove mower deck drive belt (D).

Installing Mower Deck Drive Belt:

NOTE: If necessary, see drive belt installation label on mower deck.

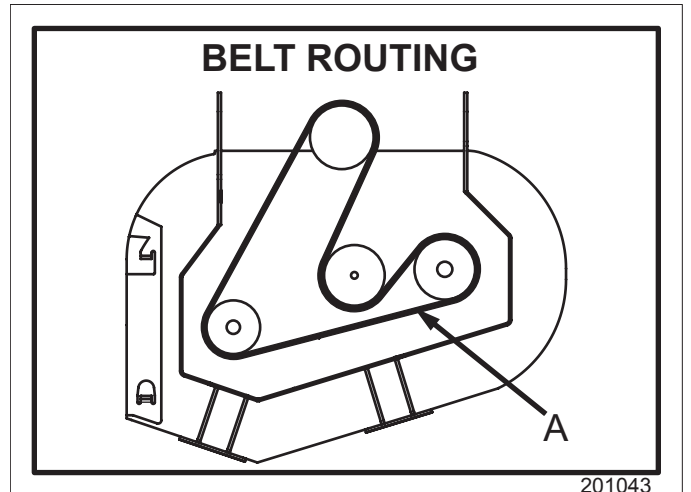

201043

1. Install replacement drive belt (A) as shown on mower deck drive belt label. Make sure drive belt is installed properly on PTO clutch sheave, spindle sheaves and idler pulleys.

SERVICE MOWER

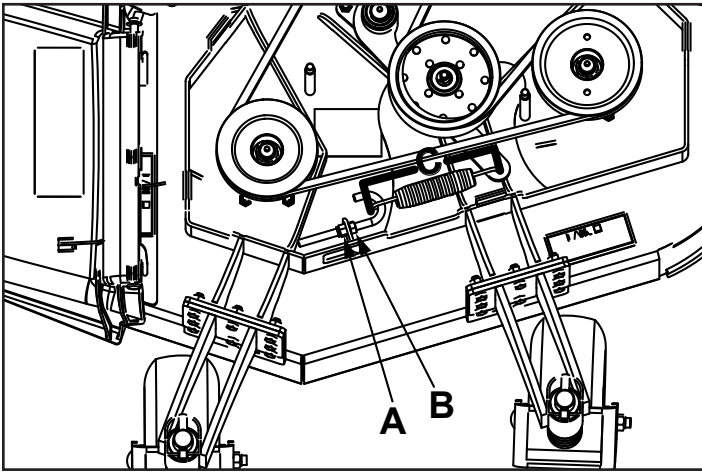

2. Connect idler tension spring and adjust tension. The length (C) of the tension spring should measure 17.5 to 18.1 cm (6 7/8 in. to 7 1/8 in.) from inside of hook to inside of hook.
3. Install both mower deck belt shields.
4. Install mower deck shield.
5. Adjust mower deck to desired cutting height.

Checking for Bent Mower Blades

CAUTION: Avoid injury! Mower blades are sharp. Always wear gloves when handling mower blades or working near blades.

Replace blades if defective. Never straighten or weld them.

1. Park machine safely. (See Parking Safely in the SAFETY section.)
2. Raise mower to highest position to access blades.

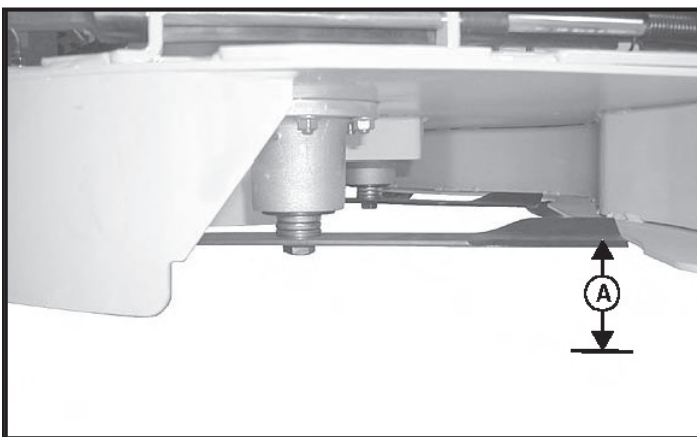

Picture Note: Mower deck with side discharge used for illustration.

3. Measure distance (A) between blade tip and flat ground surface.
4. Rotate blade 180° and measure distance between

5. other blade tip and flat ground surface.
5. Install new blade if the difference between the two measurements is more than 3 mm (1/8 in.).
6. Repeat for all blades.

Checking and Replacing Mower Blades



CAUTION: Avoid injury! Do not work near raised mower deck unless it is safely supported.

- Mower blades are sharp. Wrap blades or wear gloves when servicing.
- Before performing any service function, wait for all moving parts to stop turning.
- Disconnect battery or remove spark plug wire before making repairs.

IMPORTANT: Avoid Damage! When replacing mower blades, always use genuine Great Dane Service Parts.

NOTE: Only replace blades. Never straighten or weld them.

Checking Mower Blades

1. Park machine safely. (See Parking Safely in the Safety Section).
2. Raise the mower deck to the transport position (also the 12.7 cm [5 in.] cutting height position).
3. Raise front of machine with a safe lifting device.
 - Support with jack stands and/or wooden blocks.
4. Check mower blades:
 - Mower blades should be sharp and free of any damage.
 - Inspect blades; sharpen/balance or replace as necessary.

Replacing Mower Blades

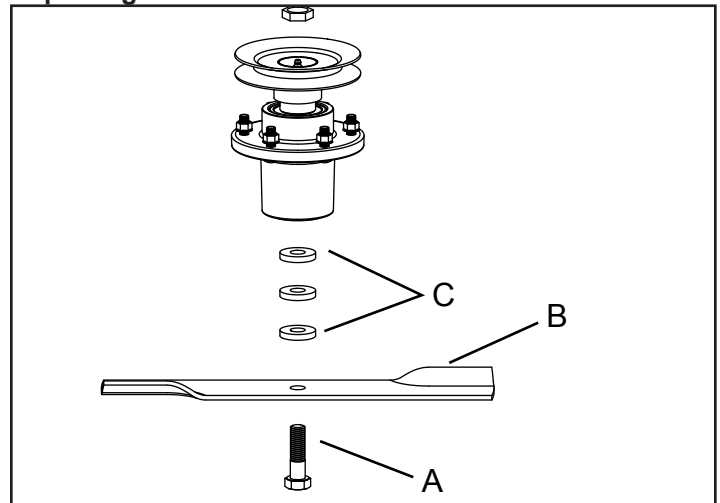

1. Remove blade bolt (A), three 1/4 in. washers (B) and

SERVICE ELECTRICAL

blade (C).

2. Install replacement blade:
 - Blade wing must face toward top of mower deck.

IMPORTANT: Avoid Damage! When installing the blade:

- Make sure the blade is properly seated on the spindle.
 - Make sure the concave side of the large washer faces towards the blade.
- Install blade bolt (A), blade (B) and three 1/4 in. washers (C).
 - Tighten blade bolt to 163 N•m (120 lb-ft).
3. Lower machine.
 4. Adjust mower deck to a desirable cutting height.

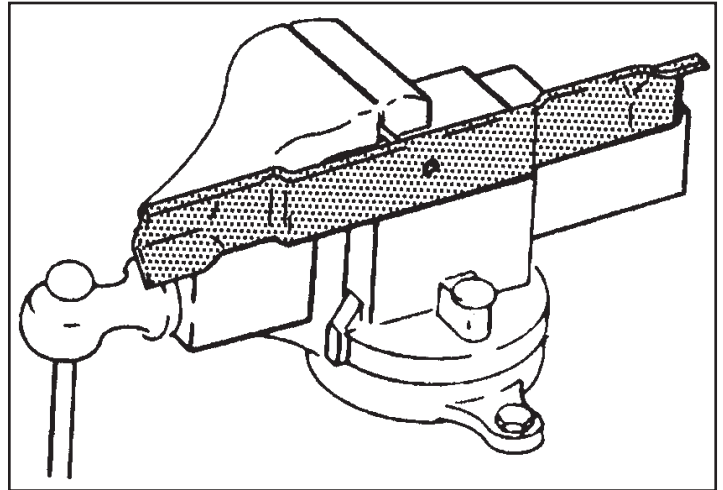

Sharpening Blades



CAUTION: Avoid injury! Mower blades are dangerous!

- Always wear gloves while working on blades.
 - Always wear safety eye protection when grinding.
- Sharpen blades with grinder, hand file, or electric blade sharpener.

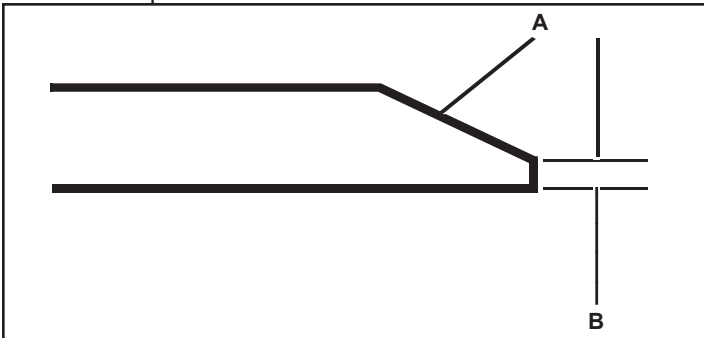

- Keep original bevel (A) when grinding.
- Blade should have 0.40 mm (1/64 in.) cutting edge (B) or less.
- Balance blades before installing.

Balancing Blades



CAUTION: Avoid injury! Mower blades are sharp. Always wear gloves when handling mower blades or working near blades.

1. Clean blade.

2. Put blade on nail in a vise. Turn blade to horizontal position.
3. Check balance. If blade is not balanced, heavy end of blade will drop.
4. Grind bevel of heavy end. Do not change blade bevel.

Service Electrical



WARNING: Battery posts, terminals and related accessories contain lead and lead components, chemicals known to the State of California to cause cancer and reproductive harm. Wash hands after handling.

Service the Battery Safely

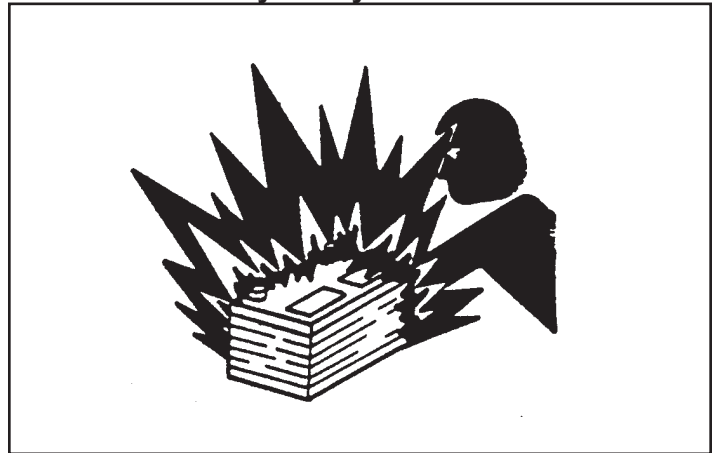

SERVICE ELECTRICAL



CAUTION: Avoid injury! Battery electrolyte contains sulfuric acid. It is poisonous and can cause serious burns:

- Wear eye protection and gloves.
- Keep skin protected.
- If electrolyte is swallowed, get medical attention immediately.
- If electrolyte is splashed into eyes, flush immediately with water for 15-30 minutes and get medical attention.
- If electrolyte is splashed onto skin, flush immediately with water and get medical attention if necessary.



The battery produces a flammable and explosive gas. The battery may explode:

- Do not smoke near battery.
- Wear eye protection and gloves.
- Do not allow direct metal contact across battery posts.
- Remove negative cable first when disconnecting.
- Install negative cable last when connecting.

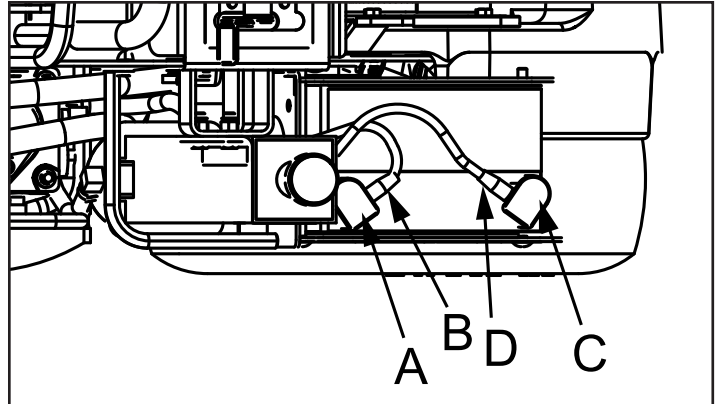

2. Slide back black cover (A) and disconnect negative (-) battery cable (B).
3. Slide back red cover (C) and disconnect positive (+) battery cable (D).

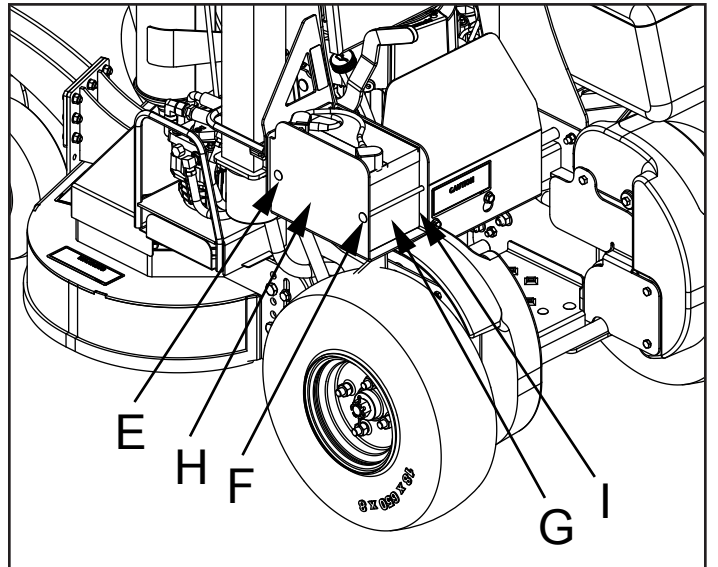

4. Loosen nut on front long carriage bolt (E).
5. Remove rear long carriage bolt (F) and nut.
6. Lift and slide battery (G) out from back of battery tray (H).
7. Inspect isolator pad (I). Replace as needed.

Installing:

1. Place isolator pad (I) in battery tray (H). Ensure that isolator pad is on the bottom and sides of battery tray.
2. Install battery (G) in battery tray (H) with positive terminal in rear.
3. Install rear long carriage bolt (F) and nut. Do not overtighten.
4. Tighten nut on long carriage bolt (E) to secure battery (G) in battery tray (H). Do not overtighten.
5. Apply dielectric grease to terminals to prevent corrosion.
6. Connect the positive (+) battery cable (D) and install

Checking the Battery (Sealed Batteries)

NOTE: Do not attempt to open, add fluid or service battery. Any attempt to do so will void warranty.

- Keep battery and terminals clean.
- Keep battery bolts tight.
- Keep small vent holes open.

IMPORTANT: Avoid Damage! The battery comes fully charged. If the machine is not used by the service expiration date indicated on the battery, charge the battery.

Recharge, if necessary, at 6–10 amperes for 1 hour.

Removing and Installing Battery

Removing:

1. Park machine safely. (See Parking Safely in the SAFETY section.)

SERVICE MISCELLANEOUS

cover (C).

7. Connect negative (-) battery cable (B) and install cover (A).

Cleaning Battery and Terminals

1. Park machine safely. (See Parking Safely in the SAFETY section.)
2. Disconnect and remove battery.
3. Wash battery with solution of four tablespoons of baking soda to one gallon of water. Be careful not to get the soda solution into the cells.
4. Rinse the battery with plain water and dry.
5. Clean terminals and battery cable ends with wire brush until bright.
6. Apply general purpose grease or silicone spray to terminal to prevent corrosion.
7. Install battery.

Using Booster Battery



CAUTION: Avoid injury! The battery produces a flammable and explosive gas. The battery may explode:

- Do not smoke or have open flame near battery.
- Wear eye protection and gloves.
- Do not jump start or charge a frozen battery. Warm battery to 16°C (60°F).
- Do not connect the negative (-) booster cable to the negative (-) terminal of the discharged battery. Connect at a good ground location away from the discharged battery.

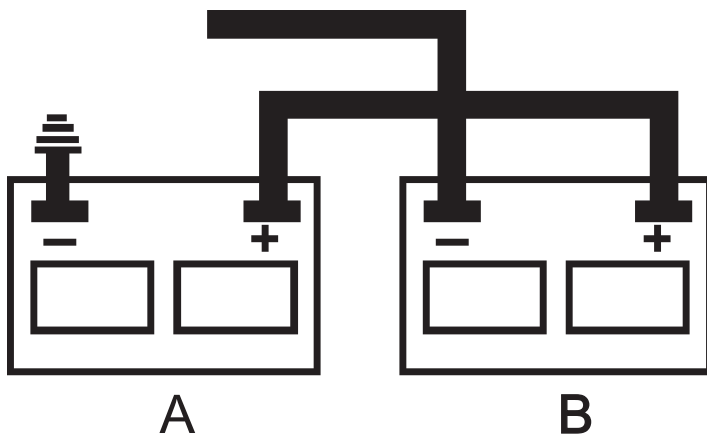

A - Booster Battery
B - Disabled Vehicle Battery

1. Connect positive (+) booster cable to booster battery (A) positive (+) post (C).
2. Connect the other end of positive (+) booster cable to the disabled vehicle battery (B) positive (+) post (D).
3. Connect negative (-) booster cable to booster battery negative (-) post (E).

IMPORTANT: Avoid Damage! Electric charge from booster battery can damage machine components. Do not install negative booster cable to machine frame. Install only to the engine block.

Install negative booster cable away from moving parts in the engine compartment, such as belts and fan blades.

4. Connect the other end (F) of negative (-) booster cable to a metal part of the disabled machine engine block away from battery.
5. Start the engine of the disabled machine and run machine for several minutes.
6. Carefully disconnect the booster cables in the exact reverse order: negative cable first and then the positive cable.

Replacing Fuse

The electric start circuit is protected by one 20 Amp fuse.

IMPORTANT: Avoid Damage! Help prevent machine circuit damage. Make sure replacement fuse is the correct size.

1. Locate electric start fuse holder under console on the machine.

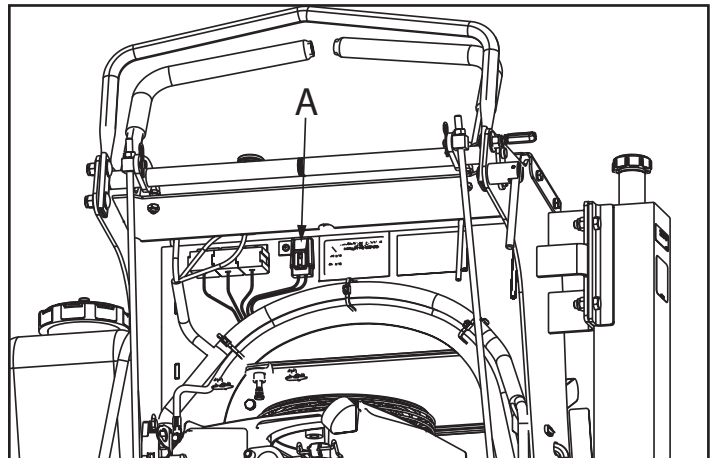

- Open fuse holder (A) and remove socket with fuse.
- Check metal clip in fuse window. Discard fuse if clip is broken.
- Install new 20 Amp fuse in socket.
- Install socket with fuse in cover. Ensure that plastic tab

SERVICE MISCELLANEOUS

of fuse holder is securely fastened to fuse socket.

Adjusting Operator Presence Switch

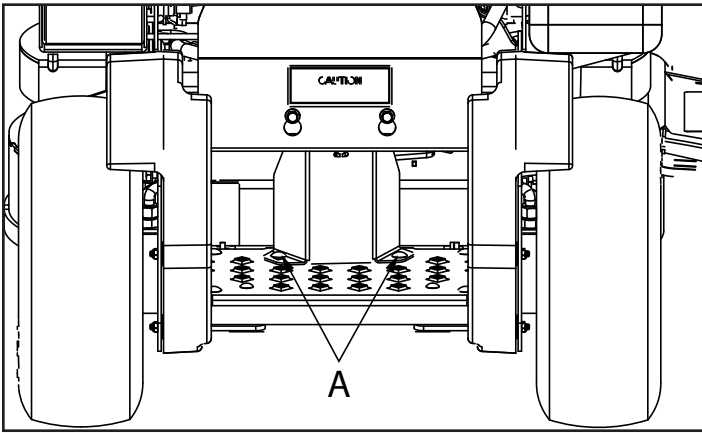

1. Remove the OPC plate covering the operator presence switch by removing the two 3/8-16n1.25 carriage bolts securing it in place.
2. Carefully cut the wire tie securing the harness to the plate.

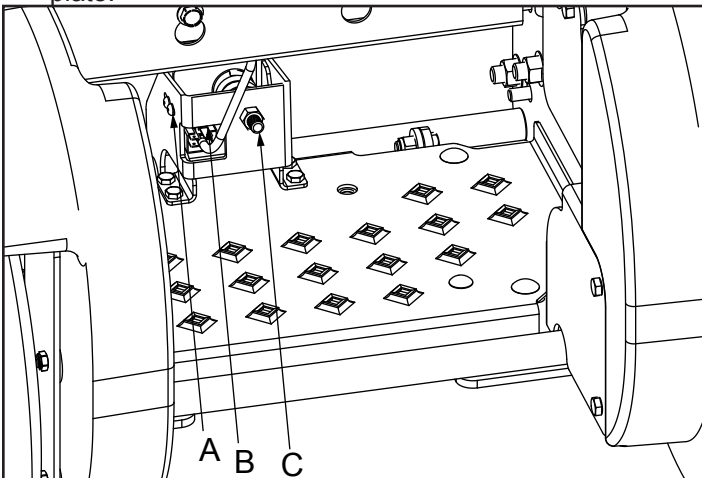

3. Loosen the two # 10 pan head screws (A) securing the safety switch (B) in place and slide the switch in or out as necessary.
4. Install the safety plate removed in step one and tie the harness to the plate again.

The switch is properly adjusted when there is 3/8" - 1/2" clearance between the rubber bumper and the support plate when there is not any pressure applied to the plate. The foot plate can be adjusted by tightening or loosening the lock nut (C) holding the compression spring in place.

Service Miscellaneous Using Proper Fuel

Use regular grade unleaded fuel with an octane rating of 87 octane or higher. Fuel blends containing up to 10% ethanol or up to 15% MTBE reformulated fuel are acceptable. Do

not use fuel or additives containing methanol as engine damage can occur.

Always use fresh, clean fuel that is purchased in a quantity that can be used within approximately 30 days, or add fuel stabilizer.

Fuel is blended to give best seasonal performance. To avoid engine performance problems such as hard starting or vapor lock, use in-season fuel. Use fuel during warm weather that was purchased during that season, and use fuel during cold weather that was purchased during that season.

Fuel can become stale in machines with engines that are used seasonally or infrequently during a season. Stale fuel can produce varnish and plug carburetor components which can affect engine performance.

Keep fuel storage container tightly covered and in a cool area out of direct sunlight. Fuel can break down and degrade if not sealed properly or exposed to sun and heat. Condensation may collect in the fuel tank because of a variety of operating or environmental conditions and, over time, may affect your machine's operation. Fill fuel tank at the end of daily use and store fuel in plastic containers to reduce condensation.

For best year-round performance and fuel-handling, add stabilizer to fuel immediately after fuel purchase. Such practice helps prevent engine performance problems and allows fuel storage in the machine all year without draining.

Filling Fuel Tank



CAUTION: Avoid injury! Fuel vapors are explosive and flammable:

- Shut engine off before filling fuel tank.
- Do not smoke while handling fuel.
- Keep fuel away from flames or sparks.
- Fill fuel tank outdoors or in well ventilated area.
- Clean up spilled fuel immediately.
- Use clean approved non-metal container to prevent static electric discharge.
- Use clean approved plastic funnel without screen or filter to prevent static electric discharge.

SERVICE MISCELLANEOUS

Important: Avoid damage! Dirt and water in fuel can cause engine damage:

- Clean dirt and debris from the fuel tank opening.
- Use clean, fresh, stabilized fuel.
- Fill the fuel tank at the end of each day's operation to keep condensation out of the fuel tank.

Use a non-metallic funnel with a plastic mesh strainer when filling the fuel tank or container.

Fill fuel tank at the end of each day's operation to prevent condensation and freezing during cold weather.

1. Park machine safely. (See Parking Safely in the SAFETY section.)
2. Allow engine to cool.
3. Remove any trash from area around fuel tank cap.
4. Remove fuel tank cap slowly to allow any pressure built up in tank to escape.
5. Fill fuel tank only to bottom of filler neck.
6. Install fuel tank cap.

Removing and Installing Rear Drive Wheels

Removing:

1. Park machine safely. (Refer to Parking Safely in the SAFETY section.)

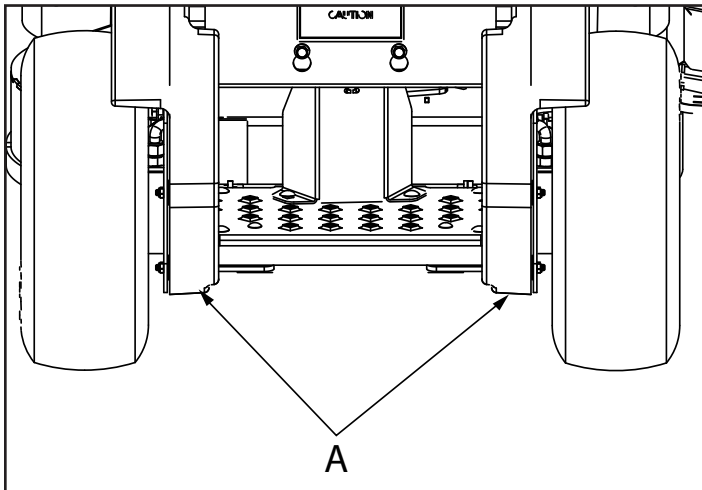

2. Lift machine with a safe lifting device centered under tire support frame (A) on the side where tire is being removed.

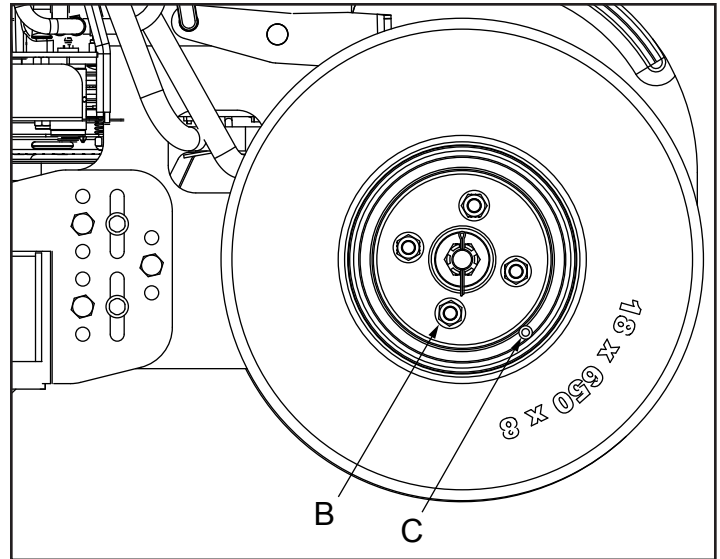

3. Remove wheel nuts (B).
4. Remove wheel.

Installing:

1. Install wheel with valve stem (C) facing out.
2. Install and tighten wheel nuts alternately until recommended torque value is reached.
 - Tighten nuts to 102 N•m (75 lb-ft).
3. Lower machine.

Removing and Installing Front Caster Wheels

Removing:

1. Park machine safely. (Refer to Parking Safely in the SAFETY section.)
2. Lift front of machine with a safe lifting device.
3. Remove nut (A) and wheel cap screw (B).
4. Remove wheel and spacers from yoke assembly (C).

Installing:

1. Install replacement wheel and original spacers.
2. Install wheel cap screw (B) and nut (A).
3. Tighten nut until wheel develops slight rolling resistance.
4. Lower machine.

Tightening Rear Drive Wheel Hardware

1. Tighten rear wheel nuts to 102 N•m (75 lb-ft).

SERVICE MISCELLANEOUS

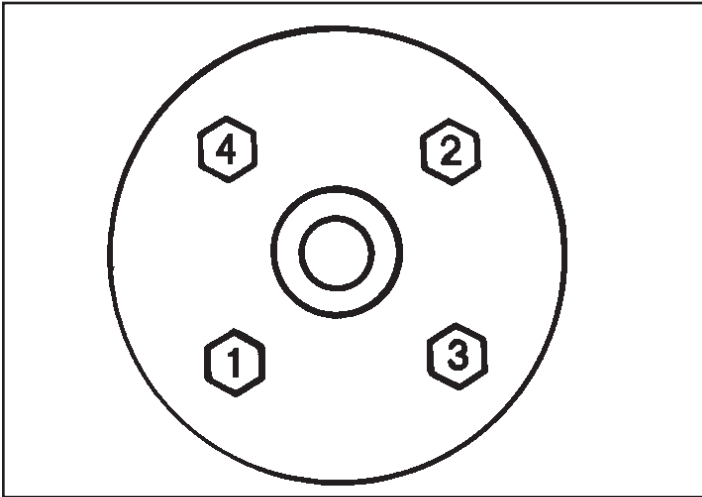

2. Tighten wheel nuts in numbered sequence shown for safe wheel installation. Tighten alternately until recommended torque value is reached.

Checking Tire Pressure

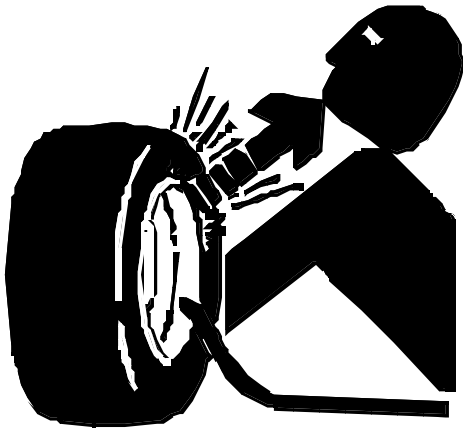

CAUTION: Avoid injury! Explosive separation of tire and rim parts is possible when they are serviced incorrectly:

- Do not attempt to mount a tire without the proper equipment and experience to perform the job.
- Do not inflate the tires above the recommended pressure.
- Do not weld or heat a wheel and tire assembly. Heat can cause an increase in air pressure resulting in an explosion. Welding can structurally weaken or deform the wheel.
- Do not stand in front or over the tire assembly when inflating. Use a clip-on chuck and extension hose long enough to allow you to stand to one side.

1. Check tires for damage.
2. Check tire pressure with an accurate gauge.
3. Add air, if necessary:

Tire Size	Pressure
Front: 11 x 4 - 5	138–173 kPa (20-25 psi)
Rear: 18 x 6.5 - 8	69–97 kPa (10–14 psi)

Servicing Caster Wheel Roller Bearings

1. Park machine safely. (See Parking Safely in the SAFETY section.)
2. Raise and securely support front of machine.

TROUBLESHOOTING

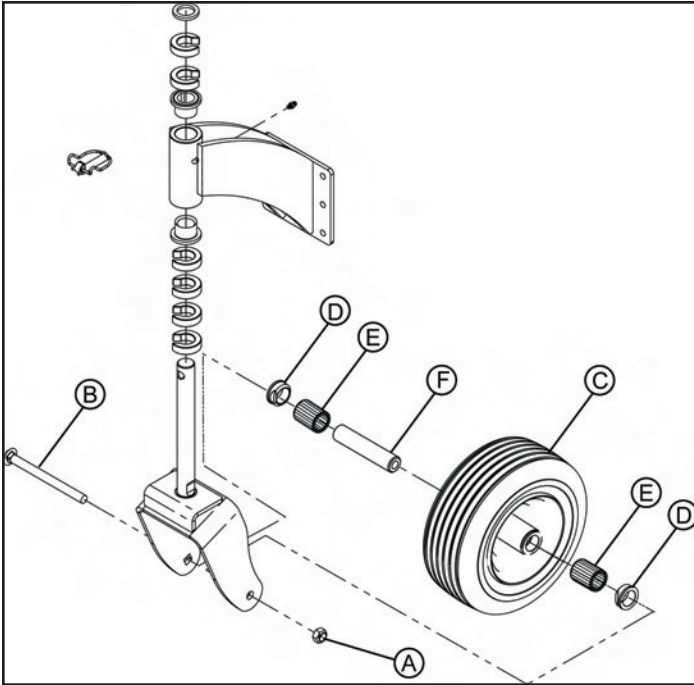

3. Remove locknut (A), cap screw (B), and wheel assembly (C).
4. Remove seals (D) and bearings (E) from wheel.
5. Clean and inspect bearings (E). Replace as needed.
6. Repack bearings with clean grease.
7. Install bearings (E) and wheel spacer (F) (if removed), and new seals (D).
8. Install wheel assembly (C), cap screw (B) and locknut (A).
9. Use a grease gun to fill hub until grease just appears at one of the seals (D).
10. Lower machine.

Cleaning and Repairing Plastic Surfaces

Your authorized dealer has the professional materials needed to properly remove surface scratches from any plastic surfaces, do not attempt to paint over marks or scratches in plastic parts.

IMPORTANT: Avoid Damage! Improper care of machine plastic surfaces can damage that surface:

- Do not wipe plastic surfaces when they are dry. Dry wiping will result in minor surface scratches.
- Use a soft, clean cloth (bath towel, diaper, automotive mitt).
- Do not use abrasive materials, such as polishing compounds, on plastic surfaces.
- Do not spray insect repellent near machine.

1. Wash surface with clean water and a mild liquid automotive washing soap.
2. Dry thoroughly to avoid water spots.

Cleaning and Repairing Metal Surfaces

Cleaning:

Follow automotive practices to care for your vehicle painted metal surfaces. Use a high-quality automotive wax regularly to maintain the factory look of your vehicle's painted surfaces.

Repairing Minor Scratches (surface scratch):

1. Clean area to be repaired thoroughly.

IMPORTANT: Avoid damage! Do not use rubbing compound on painted surfaces.

1. Use automotive polishing compound to remove surface scratches.
2. Apply wax to entire surface.

Repairing Deep Scratches (bare metal or primer showing):

1. Clean area to be repaired with rubbing alcohol or mineral spirits.
2. Use paint stick with factory-matched colors available from your authorized dealer to fill scratches. Follow directions included on paint stick for use and for drying.
3. Smooth out surface using an automotive polishing compound. Do not use power buffer.
4. Apply wax to surface.

Troubleshooting

Using Troubleshooting Chart

If you are experiencing a problem that is not listed in this chart, see your authorized dealer for service.

When you have checked all the possible causes listed and you are still experiencing the problem, see your authorized dealer.

If

Poor Engine Performance

Check

Fuel:

- Dirt in fuel system or fuel is old. Replace fuel with fresh stabilized fuel. Obtain fuel from another supplier before suspecting machine problems. Suppliers blend fuels differently and changing suppliers will generally solve any performance problems.
- Fuel blended with alcohol or ether may contribute to performance problems by causing gum and varnish deposits, especially if fuel is stored for several weeks or more. Obtain fresh fuel.

STORAGE

Engine Will Not Start Or Is Hard To Start

- Park brake lever not in the proper position.
- OPC switch not depressed. Stand on platform or adjust switch.
- Check that motion control levers are in neutral and neutral switches are correctly adjusted.
- PTO engaged.
- Stale or improper fuel/fuel level.
- Plugged fuel filter.
- Plugged air intake filter.
- Spark plug wires loose or disconnected.
- Spark plugs not gapped correctly.
- Blown fuse.
- Electrical problem – dead battery.
- Choke adjusted incorrectly. See your authorized dealer.

Engine Will Not Slow Idle

- Carburetion problems. See your authorized dealer.
- Bent or kinked throttle cable.
- Bent governor control.
- Incorrect governor idle control.

Engine Runs Rough or Stalls

- Plugged fuel filter.
- Plugged air intake system.
- Fuel cap vent dirty.
- Stale or improper fuel/fuel level.
- Spark plugs not gapped correctly.
- Replace spark plugs.
- Choke adjusted incorrectly. See your authorized dealer.

Engine Knocks

- Engine oil level low.
- Reduce load. (Slower ground speed.)
- Fuel is bad. Fill tank with fresh fuel, correct octane.
- Idle speed too slow.

Engine Overheats

- Clean cooling fins.
- Low oil level.
- Do not operate at slow idle. Operate at fast idle.
- Cooling air intake screen is dirty.

Engine Lacks Power

- Plugged carburetor air intake filter.
- Plugged air intake filter.
- Operating at too fast ground speed for conditions.
- Reduce load.
- Plugged air intake system.
- Plugged fuel filter.
- Improper type of fuel. Drain tank and fill with correct fuel.
- Clean cooling fins to help prevent overheating.
- Replace spark plugs.
- Find and correct oil leaks.

Engine Uses Too Much Oil

- Incorrect engine oil.
- Plugged oil filter.
- Plugged air intake filter.
- Worn engine components.
- Throttle lever should be at low idle for thirty seconds before turning off machine.
- Improper type of fuel.

Engine Backfires Through Muffler

High Fuel Consumption

- Plugged air intake system.
- Operating at too fast ground speed for conditions.
- Improper valve clearance. See your authorized dealer.
- Restricted air intake system.

Other Symptoms

- See engine manufacturer's owner's manual provided with your machine for additional information.

Electrical System

If Starter Will Not Work

- Check**
- Blown fuse.
 - OPC Switch faulty or not adjusted properly.
 - Park brake switch is faulty.
 - Loose or corroded battery connections.

STORAGE

	<ul style="list-style-type: none"> • Neutral switches faulty or not adjusted properly. See your authorized dealer. • Key switch or starter faulty. See your • authorized dealer. • PTO engaged. • Motion control levers and park brake lever not in proper position. 	<p>Machine Creeps With Engine Running and Motion Control Levers in a Neutral Position</p>	<ul style="list-style-type: none"> • Needs motion control linkage adjustment.
<p>Battery Will Not Charge</p>	<ul style="list-style-type: none"> • Loose or corroded connections. 	<p>Park Brake</p>	<ul style="list-style-type: none"> • Needs Adjustment.
<p>PTO Switch Does Not Work</p>	<ul style="list-style-type: none"> • Blown fuse or fusible link. See your authorized dealer. • Blown fuse. 	<p>If Park Brake Not Working Correctly</p>	<p>Check</p> <ul style="list-style-type: none"> • Park brake out of adjustment – adjust linkage.
<p>Starter Turns Slowly</p>	<ul style="list-style-type: none"> • PTO switch faulty. • Loose or corroded battery connections. • Low battery power-charge battery. • Engine oil viscosity too heavy. • Hydraulic pump linkage out of adjustment-pumps engaged. 	<p>Steering</p>	
<p>Machine</p>		<p>If Steering Not Working</p>	<p>Check</p> <ul style="list-style-type: none"> • Pump free-wheel valves partially open. • Improper tire inflation. • Hydrostatic transmission oil level low. • Traction drive loose or broken. • Hydraulic pump or wheel motor faulty.
<p>If Excessive Machine Vibration</p>	<p>Check</p> <ul style="list-style-type: none"> • Engine speed too slow. • Deck drive belt not tensioned correctly. • Mower blades not balanced. 	<p>Mower Deck</p>	
<p>Machine Will Not Move With Engine Running</p>	<ul style="list-style-type: none"> • Park brake locked. • Transmission oil level low. • Transmission oil cold – allow engine to warm up. • Pump drive belt slipping or broken. • Pump drive belt spring broken. • Pump free-wheel valves open. • Transmission problems. See your authorized dealer. 	<p>If Discharge Chute Plugged</p>	<p>Check</p> <ul style="list-style-type: none"> • Grass is wet-mow grass only when dry. • Raise cutting height. • Mow with engine at full fast throttle. • Ground speed too fast for conditions. • Correct installation of deck drive belt. • Run engine at fast throttle.
		<p>Mower Deck Vibrates</p>	<ul style="list-style-type: none"> • Loose hardware. • Check/replace deck drive belt. • Blade bolts are loose. • Blades are bent or worn. • Sharpen and balance blades.

ASSEMBLY

Mower Blades Do Not Engage

- Remove belt shields and clean debris from sheaves.
 - Check sheaves for proper alignment or damage. See authorized dealer.
 - Deck drive belt slipping or broken.
 - Deck belt tension spring not installed or broken.
 - PTO switch faulty.
 - Fuse blown.
 - Loose electrical connections.
 - PTO clutch faulty.
 - Mower deck not properly leveled.
5. Wash the machine and apply wax to metal and plastic surfaces.
 6. Run machine for five minutes to dry belts and pulleys.
 7. Apply light coat of engine oil to pivot and wear points to prevent rust.
 8. Lubricate grease points and check tire pressure.

Mower Mows Unevenly

- Ground speed too fast for conditions.
- Run engine at fast throttle.
- Reduce ground speed when making turns.
- Sharpen or replace blades.
- Change mowing pattern.
- Check air pressure in all traction unit tires.
- Anti-scalp rollers not adjusted correctly.

Storage Storing Safety



CAUTION: Avoid injury! Fuel vapors are explosive and flammable. Engine exhaust fumes contain carbon monoxide and can cause serious illness or death:

Run the engine only long enough to move the machine to or from storage.

Do not store vehicle with fuel in the tank inside a building where fumes may reach an open flame or spark.

Allow the engine to cool before storing the machine in any enclosure.

Preparing Machine for Storage

1. Repair any worn or damaged parts. Replace parts if necessary. Tighten loose hardware.
2. Repair scratched or chipped metal surfaces to prevent rust.
3. Remove grass and debris from machine.
4. Clean under the deck and remove grass and debris

5. from inside chute and bagger.
6. Run machine for five minutes to dry belts and pulleys.
7. Apply light coat of engine oil to pivot and wear points to prevent rust.
8. Lubricate grease points and check tire pressure.

Preparing Fuel and Engine For Storage Fuel:

If you have been using "Stabilized Fuel," add stabilized fuel to tank until the tank is full.

NOTE: Filling the fuel tank reduces the amount of air in the fuel tank and helps reduce deterioration of fuel.

If you are not using "Stabilized Fuel:"

1. Park machine safely in a well-ventilated area. (See Parking Safely in the SAFETY section.)

NOTE: Try to anticipate the last time the machine will be used for the season so very little fuel is left in the fuel tank.

2. Turn on engine and allow to run until it runs out of fuel.
3. For machines equipped with key switch, turn key to off position.

IMPORTANT: Avoid Damage! Stale fuel can produce varnish and plug carburetor or injector components and affect engine performance.

- Add fuel conditioner or stabilizer to fresh fuel before filling tank.
4. Mix fresh fuel and fuel stabilizer in separate container. Follow stabilizer instructions for mixing.
 5. Fill fuel tank with stabilized fuel.
 6. Run engine for a few minutes to allow fuel mixture to circulate through carburetor on gas engine or fuel injectors on diesel engine.

Engine:

Engine storage procedure should be used when vehicle is not to be used for longer than 60 days.

1. Change engine oil and filter while engine is warm.
2. Service air filter if necessary.
3. Clean debris from engine air intake screen.
4. On gas engines:
 - Remove spark plugs. Put 30 mL (1 oz) of clean engine oil in cylinders.
 - Install spark plugs, but do not connect spark plug wires.
 - Crank the engine five or six times to allow oil to be distributed.
5. Clean the engine and engine compartment.
6. Remove battery.
7. Clean the battery and battery posts. Check the electrolyte level, if your battery is not maintenance free.
8. Close fuel shut-off valve, if your machine is equipped.
9. Store the battery in a cool, dry place where it will not freeze.

SPECIFICATIONS

NOTE: The stored battery should be recharged every 90 days.

10. Charge the battery.

IMPORTANT: Avoid Damage! Prolonged exposure to sunlight could damage the hood surface. Store machine inside or use a cover if stored outside.

11. Store the vehicle in a dry, protected place. If vehicle is stored outside, put a waterproof cover over it.

Removing Machine From Storage

1. Check tire pressure.
2. Check engine oil level.
3. Check battery electrolyte level, if your battery is not maintenance free. Charge battery if necessary.
4. Install battery.
5. On gas engines: Check spark plug gap. Install and tighten plugs to specified torque.
6. Lubricate all grease points.
7. Open fuel shut-off valve, if your machine is equipped.
8. Run the engine 5 minutes without the mower or any attachments running to allow oil to be distributed throughout engine.
9. Be sure all shields and guards or deflectors are in place.

Assembly Connect Handles

The handles are disconnected and rotated forward during assembly to allow for proper fitment into the shipping container.

1. Rotate the handles up.

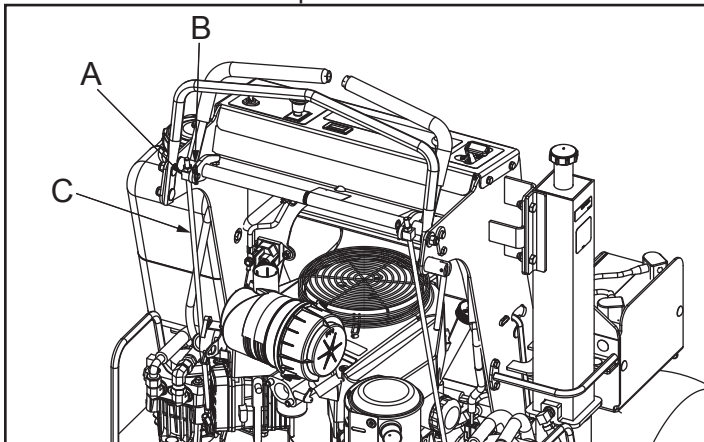

2. Connect the pump control arm (C) to the handle weldment by inserting the adjustment block (A) into the handle weldment and securing with the hairpin clip (B).
3. Set the speed control bar to desired speed and lock.

Check Hydraulic Oil Level

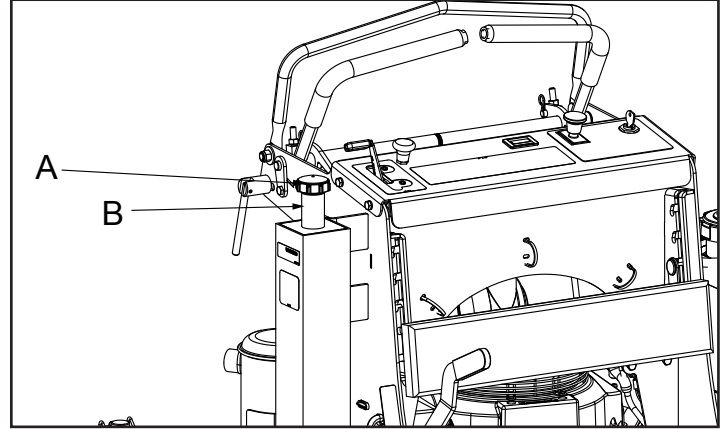

1. Clean area around dipstick cap (A).
2. Remove dipstick cap (A). Wipe dipstick clean.
NOTE: Do not tighten dipstick cap when checking oil level.
3. Insert dipstick in filler neck (B). Do not tighten cap.
4. Remove dipstick. Check oil level on dipstick. Oil level should be between the ADD and FULL marks on dipstick.
 - If oil level is below ADD mark, fill to proper level.
 - If oil level is above FULL mark, drain to proper level.
5. Insert dipstick. Tighten cap.

Check Engine Oil Level

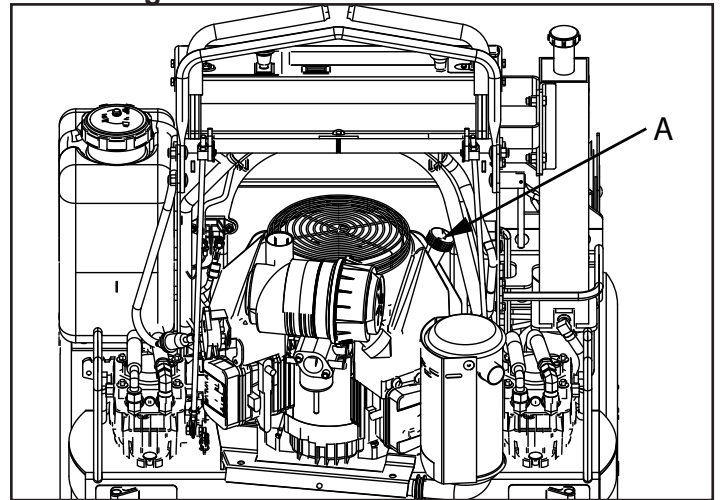

1. Clean area around dipstick cap (A).
2. Remove dipstick cap (A) from tube. Wipe dipstick clean.
NOTE: Do not tighten dipstick cap when checking oil level.
3. Insert dipstick in tube. Do not tighten cap.
4. Remove dipstick. Check oil level on dipstick. Oil level should be between the ADD and FULL marks.

GETTING QUALITY SERVICE

- If oil level is below ADD mark, fill to proper level.
 - If oil level is above the FULL mark, drain to proper level.
5. Insert dipstick. Tighten cap.

Connect Battery

CAUTION: Avoid injury! Prevent Battery Explosions:

- Keep sparks, lighted matches, and open flame away from the top of battery. Battery gas can explode.
- Never check battery charge by placing a metal object across the posts. Use a volt-meter or hydrometer.
- Do not charge a frozen battery; it may explode. Warm battery to 16 degrees C (60 degrees F).

1. Connect positive (red) cable to battery positive (+) terminal. Install red terminal cover (A).
2. Connect negative (black) cable to battery negative (-) terminal. Install black terminal cover (B).

Check Machine Safety Systems

Perform safety system check to make sure the electronic safety interlock circuit is functioning properly.

Specifications

Engine

Note: See engine manufacturer's owner's manual provided with your machine for engine specifications.

Drivetrain

Type..... Dual Hydrostatic Pumps.....Hydro-Gear PG-1KDA-D61 - PG-1HDA-D41
Wheel Motors.....Hydro-Gear HGD-12-7172
Number of Speeds.....Infinitely Variable

Electrical System

Charging System..... 15 Amp
Ignition.....Flywheel
Starter.....Solenoid Shift

Fuel System

Fuel Type.....Gasoline, Regular Unleaded
Fuel Tank Location.....On Right Side of Operator
Fuel Capacity22.7 L (6.0 gal)

Steering and Brakes

Steering.....Dual Control Levers
Steering.....Hydraulic
Park Brake.....Tire Contact

Tires

Rear.....18 x 6.5 - 8
Front.....11 x 4 - 5
Inflation Rear (Maximum).....69–97 kPa (10–14 psi)
Inflation Front (Maximum).....138–173 kPa (20-25 psi)

Battery

Voltage.....12-volt
CCA.....270-amp
Reserve Capacity.....67 minutes
BCI Group Size.....U1

Capacities

Fuel Tank.....18.9 L (5 gal)
Hydraulic Oil (With Filter) 3.1 L (3.3 qt.)
Engine Oil (With Filter) 1.9 L (2.0 qt.)

Travel Speeds at Full Engine RPM

Forward.....0–14 km/h (0–8.7 mph)
Reverse.....0–6.4 km/h (0–4 mph)

Dimensions

Overall Height.....1.47 m (47 in.)
Overall Length.....1.48 m (58.5 in.)
Overall Width (with chute up)......89 m (35 in.)
Overall Width (with chute down).....1.19 m (47 in.)

Recommended Lubricants

Engine Oil.....See Applicable Engine Manual
Hydraulic Oil.....5W-50 or 15W-50 All Synthetic Oil
Grease: (This may change for high-speed applications such as cutting units)
All-Purpose Grease with an NLGI Grade No. 2 Rating
(Specifications and design subject to change without notice.)

Getting Quality Service

Service Literature

If you would like to order a copy of the Parts Catalog or Operator Manual for this machine, contact your Great Dane Dealer. Parts catalogs and operator manuals are also available online at GreatDane.com.

Parts

We recommend Great Dane quality parts available at your Great Dane dealer.

Part numbers may change, use part numbers listed below when you order. If a number changes, your dealer will have the latest number.

When you order parts, your Great Dane dealer needs your machine serial number and engine serial number. These are the numbers that you recorded in the Product Identification section of this manual.

GETTING QUALITY SERVICE

Great Dane Quality Continues with Quality Service

Great Dane provides a process to handle your questions or problems, should they arise, to ensure that product quality continues with your authorized Great Dane dealer's parts and service support.

Follow the steps below to get answers to any questions you may have about your product.

Refer to your attachment and machine operator manuals.

Contact your authorized Great Dane dealer with unanswered questions.

Part Numbers

Item	Part Number
Mower Blades:	
34-Inch Deck - LH Blade	GDU10231
34-Inch Deck - RH Blade	GDU10230
Hydraulic Oil Filter	GDU10137
Battery	191832
Fuse - 20 amp	57M7120
Belts:	
Hydraulic Drive Belt	201009
34-Inch Mower Deck Belt	201010

(Part numbers are subject to change without notice. Part Numbers may be different outside the U.S.A.)

HYDRAULIC SCHEMATIC

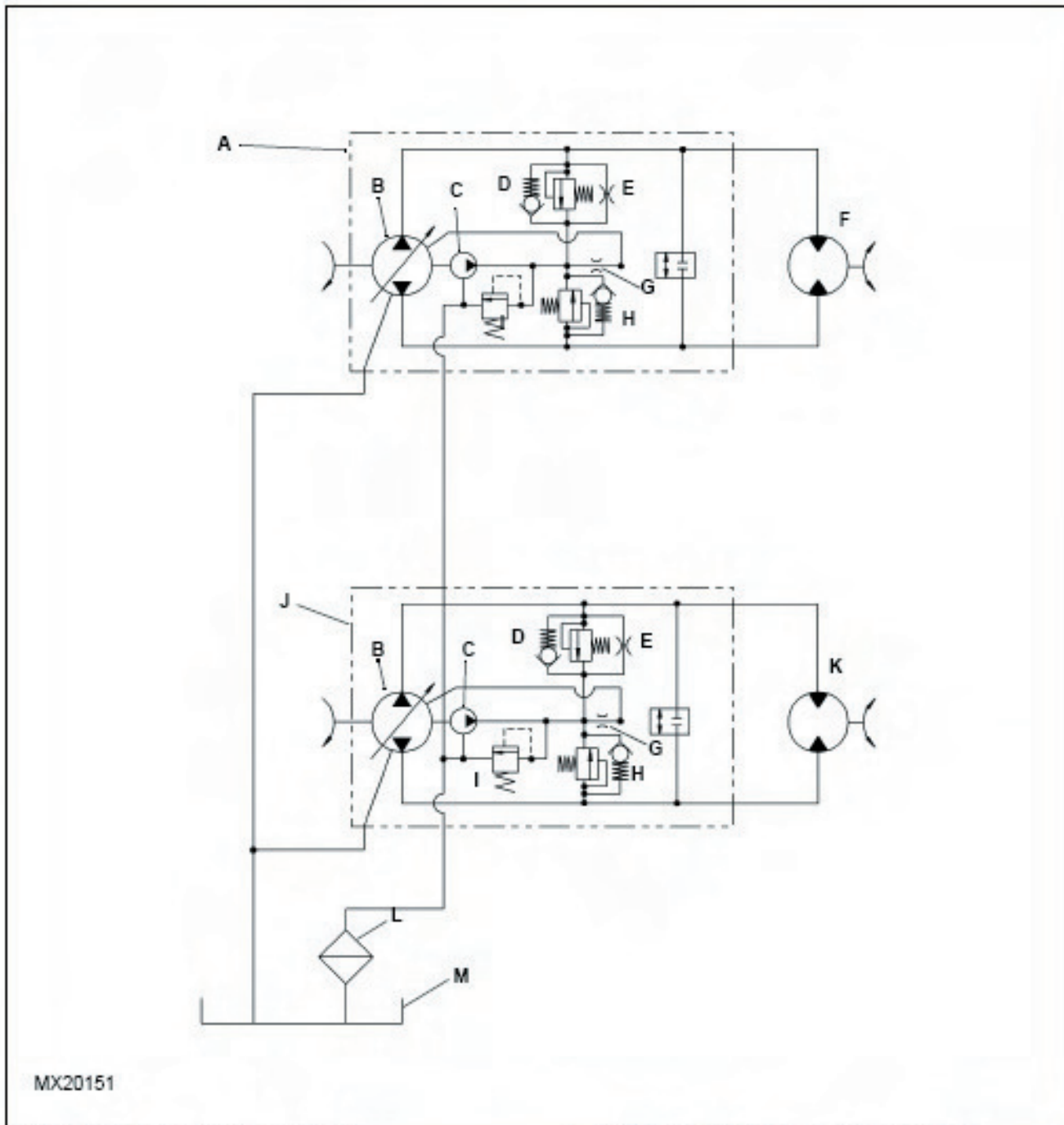

MX20151

- A. Left Hydrostatic Pump Assembly
- B. Pump Block
- C. Charge Pump
- D. System Charge Check Shock Valve (Reverse)
- E. Manual Bypass
- F. Left Wheel Motor
- G. Cooling Orifice
- H. System Charge Check Shock Valve (Forward)
- I. Charge Relief Valve
- J. Right Hydrostatic Pump Assembly
- K. Right Wheel Motor
- L. Inlet Filter
- M. Hydraulic Reservoir

NOTES

MAIN FRAME ASSEMBLY

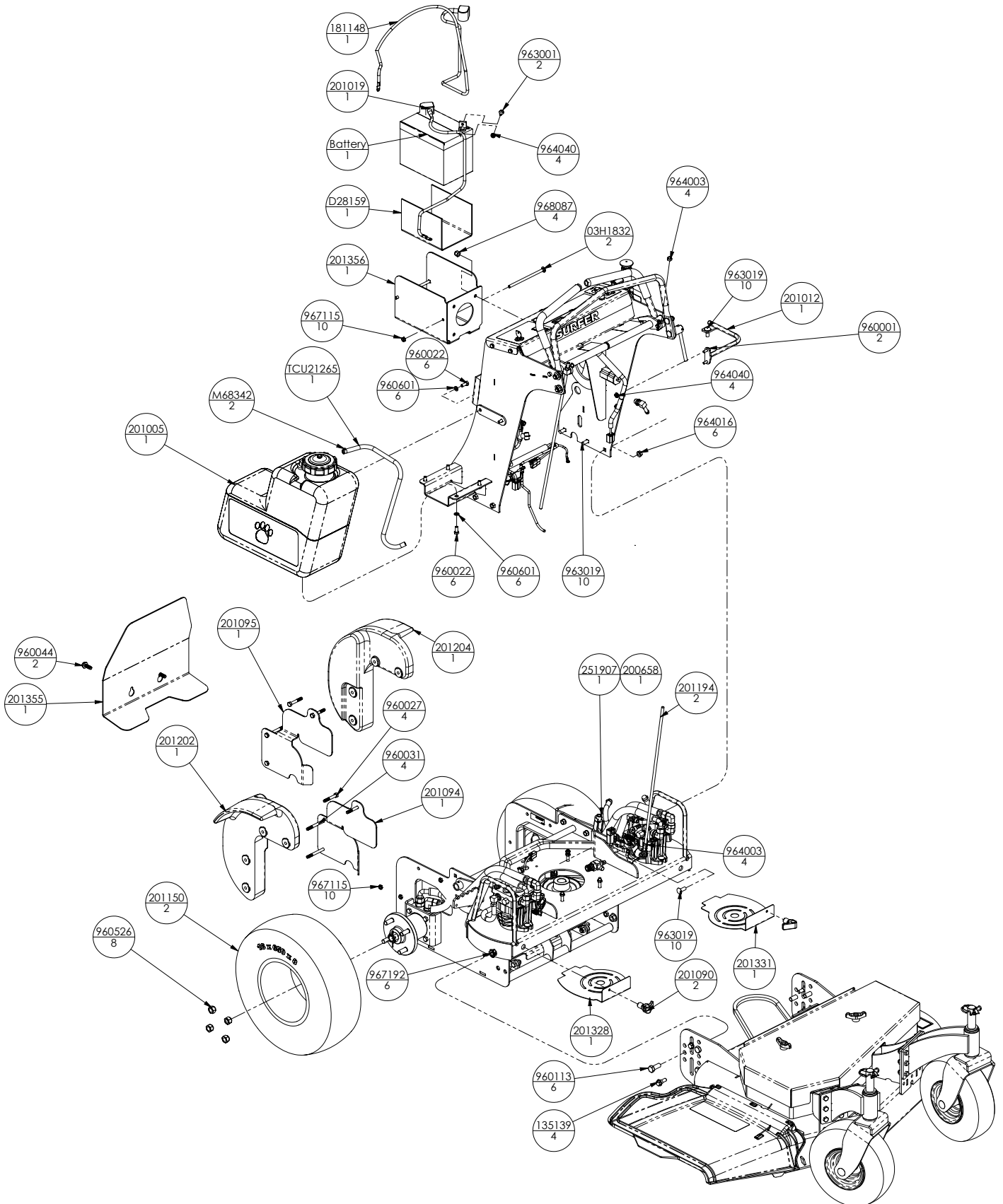

MAIN FRAME ASSEMBLY

PART NO	QTY	DESCRIPTION
D28159	1	STRIP, BATTERY INSULATOR
M68342	2	CLAMP, HOSE (RED) #
TCU21265	1	HOSE, 1/4" ID LOW PERM FUEL 50
03H1832	2	BOLT, 5/16-18 X 6.00 CRG 2 Y
135139	4	BOLT, 1/2 X 1.06 X 3/8-16 SLD 5 Y
181148	1	CABLE, BATTERY STARTER - 48"
BATTERY	1	BATTERY, 12V-U1-CCA270MIN
200658	1	PIN, CVS SPG 3/8" YOKE SPEC Y
201005	1	TANK, FUEL PUPPY PAW ASSEMBLY
201012	1	WLDT, RESERVIOR GUARD
201019	1	CABLE, BATTERY - 25" GROUND
201356	1	CONSOLE BATTERY BRACKET
201090	2	LATCH, BECKSON
201331	1	SHIELD, LH PUMP
201328	1	SHIELD, RH PUMP
201094	1	SHIELD, RH MOTOR
201095	1	SHIELD, LH MOTOR
201150	2	ASSY, TIRE/WHL 18/6.5X8 SLVR
201355	1	SHIELD, ENGINE
201194	2	ROD, CONTROL 5/16 X 22.75 Y
201202	1	RH CAST WEIGHT MACHINED
201204	1	LH CAST WEIGHT MACHINED
251907	1	YOKE, 3/8-24 RH ADJUSTABLE
960001	2	BOLT, 1/4-20 X .750 HEX 5 Y
960022	6	BOLT, 5/16-18 X .750 HEX 5 Y
960027	4	BOLT, 5/16-18 X 2.00 HEX 5 Y
960031	4	BOLT, 5/16-18 X 3.00 HEX 5 Y
960044	2	BOLT, 3/8-16 X 1.00 FGH 8 Y
960113	6	BOLT, 1/2-13 X 1.25 HEX 5 Y
960526	8	NUT, 1/2-20 LUG C
960601	6	WASHER, .313 MED SPRG LOCK Y
963001	2	BOLT, 1/4-20 X .625 WSH Y
963019	10	BOLT, 3/8-16 X 1.00 CRG 5 SN Y
964003	4	NUT, 5/16-24 STD HEX GR5 Y
964016	6	LOCKNUT, 3/8-16 WHIZ Y
964040	4	LOCKNUT, 1/4-20 WHIZ Y
967115	10	LOCKNUT, 5/16-18 NYLOC Y
967192	6	LOCKNUT, 1/2-13 WHIZ GR5 Y
968087	4	LOCKNUT, 3/8-16 NYLOC Y

HYDRAULIC AND HANDLE ASSEMBLY

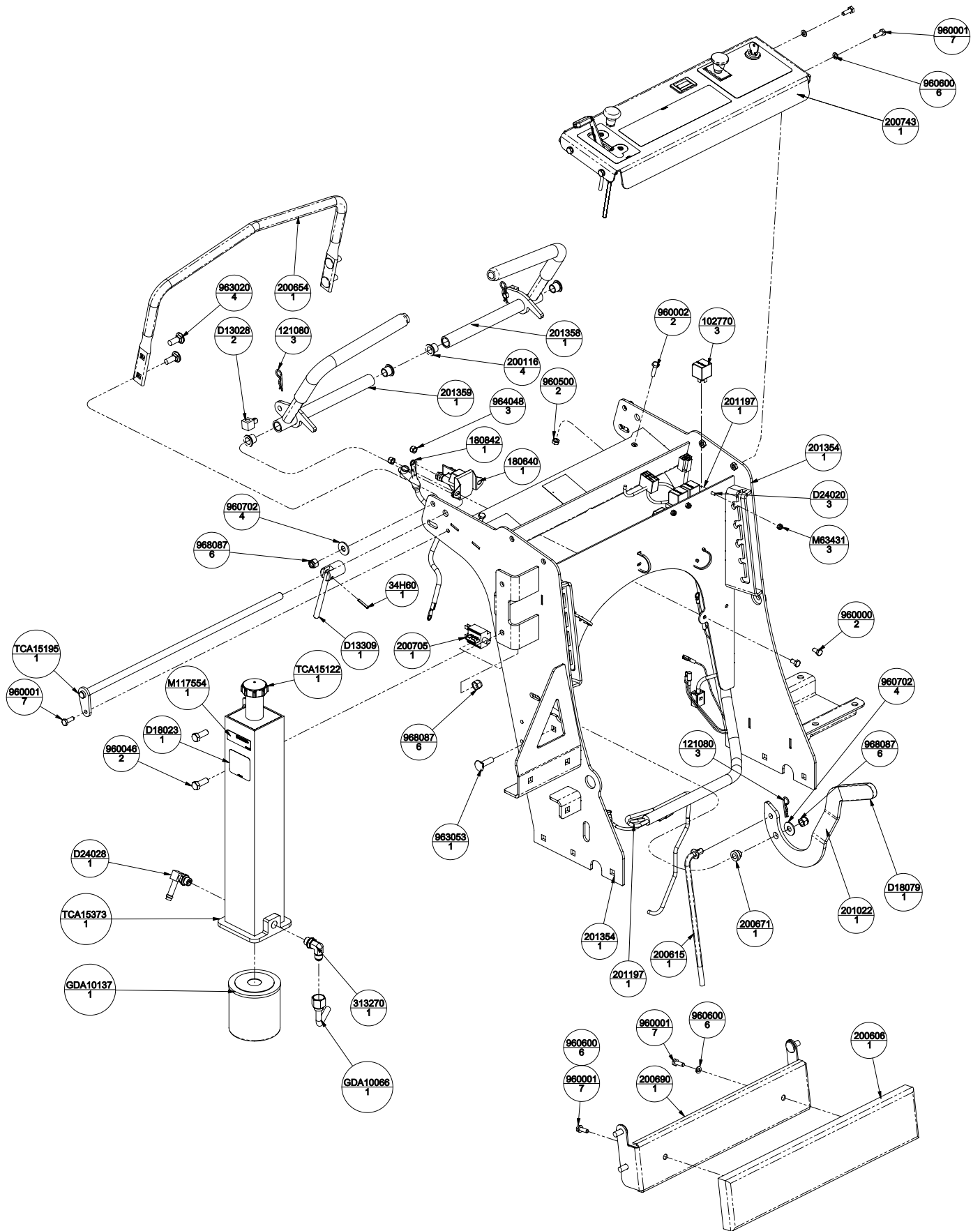

HYDRAULIC AND HANDLE ASSEMBLY

PART NO	QTY	DESCRIPTION
D13028	2	SWIVEL ADJUSTER
D13308	1	BASE, LOCK LEVER Y
D13309	1	LEVER, LOCK Y
D18023	1	DECAL, HYDRO OIL SPECS.
D18079	1	GRIP, PVC .250 X 1.00 X 3.63
D18093	2	GRIP, CONTROL
D24020	3	SCREW, 8-32X .50 PAN PHL Y
D24028	1	FTG, 90 9/16 MOR X 3/8 HOSE
GDA10066	1	ELBOW, FITTING
GDA10137	1	FILTER, OIL
M117554	1	DECAL, WARNING - HOT SURFACES
M63431	3	NUT, 8-32 ELASTIC STOP
TCA15122	1	CAP, FILLER OIL
TCA15195	1	WLDT, PIVOT ROD Y
TCA15373	1	WLDT, RESERVIOR HYDRAULIC
TCU15907	1	DECAL, WARNING, SLOPE
TCU15910	1	DECAL, DIRECTIONAL CONTROL
102770	3	RELAY, ISO MINI ELEC.
111910	3	CABLE TIE, .15 X 8.50
121080	3	PIN, HAR .091 X 1.63 5/16-1/2 Y
180640	1	SOLENOID, 12 V STARTER
180842	1	CABLE, 12" STARTER
200037	1	DECAL, PATENT COVERED
200116	4	BRG, FLG .500X.620X.500 BRNZ
200606	1	PAD, THIGH
200615	1	LINK. BRAKE Y
200743	1	CONTROL PANEL S/O
200654	1	HANDLE, SUPPORT
200671	1	BUSHING, BRAKE PIVOT Y
200690	1	WLDT, THIGH PAD BRACKET
200705	1	SWITCH, NO-NO-NC GREY PLUNGER
201022	1	BRAKE LEVER, OFFSET
201354	1	WLDT, CONSOLE 34
201358	1	WLDT, RH CONTROL LEVER
201359	1	WLDT, LH CONTROL LEVER
201197	1	HARNESS, WIRING
313270	1	FTG, 90 9/16 MOR X 9/16 MJIC
34H60	1	PIN, SPRING
960000	2	BOLT, 1/4-20 X .500 HEX 5 Y
960001	7	BOLT, 1/4-20 X .750 HEX 5 Y
960002	2	BOLT, 1/4-20 X 1.00 HEX 5 Y
960046	2	BOLT, 3/8-16 X 1.00 HEX 5 Y
960500	2	NUT, 1/4-20 STD HEX GR5 Y
960600	6	WASHER, .250 MED SPRG LOCK Y
960702	4	WASHER, .375 REG FLAT Y
963020	4	BOLT, 3/8-16 X 1.00 CRG 5 Y
963053	1	BOLT, 3/8-16 X 1.25 CRG 5 Y
964048	3	LOCKNUT, 1/4-20 NYLOC Y
968087	6	LOCKNUT, 3/8-16 NYLOC Y

ENGINE, HYDRAULIC AND MAINFRAME ASSEMBLY

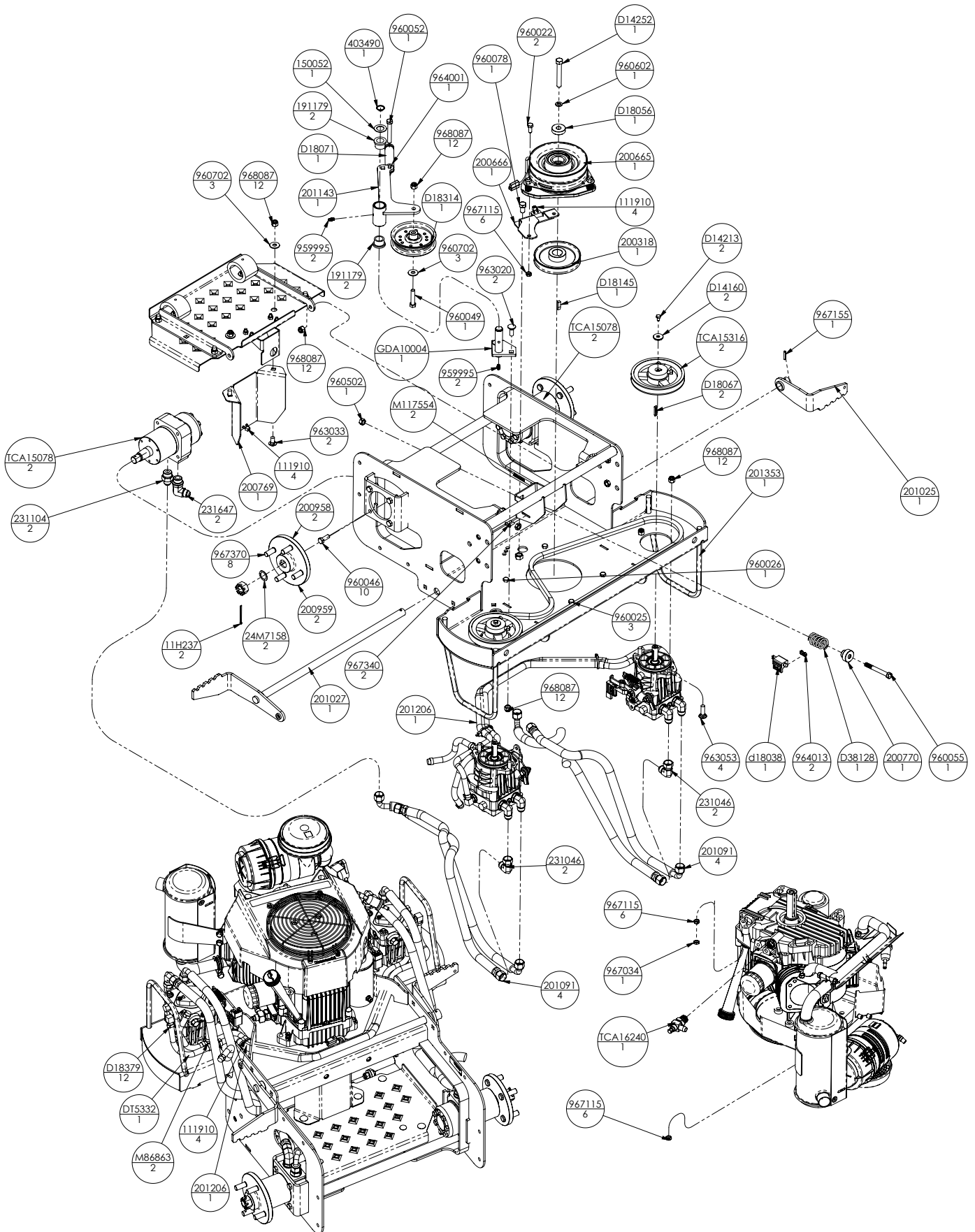

ENGINE, HYDRAULIC AND MAINFRAME ASSEMBLY

PART NO	QTY	DESCRIPTION
DT5332	1	HOSE, 3/8 SAE30R7 FUEL & OIL
D14160	2	WASHER, .250 WIDE HEAVY FLAT Y
D14213	2	BOLT, M6 X 1.00 X 10 HEX 8.8 Y
D14252	1	BOLT, 7/16-20X3.00 HEX 5 Y
d18038	1	SWITCH (N.O.)
D18056	1	SPACER, .468 X 1.38 X .375 Y
D18067	2	KEY, M5 X M5 X M30 RD
D18071	1	SPRING, EXT .900X.135X4.50 Y
D18314	1	PULLEY, V-BELT 4.00X.379 W/BRG
D18379	12	CLAMP, HOSE - 1/2" PINCH
D38128	1	SPRING, COM 1.22X.162X2.50 Y
GDA10004	1	WLDT, PIVOT IDLER MOUNT
M117554	2	DECAL, WARNING - HOT SURFACES
M86863	2	FTG, TUN 3/8 HOSE
TCA15078	2	MOTOR, WHEEL HGM-12P-7172
TCA15316	2	ASSY, PUMP PULLEY W/SET SCREW
TCA16240	1	FITTING, OIL DRAIN
11H237	2	PIN, COT .125 X 2.00 EXTP Y
111910	4	CABLE TIE, .15 X 8.50
150052	1	BUSHING, MACH .750X1.25X.048 Y
191179	2	BRG, FLG .750 X 1.00 X .750 BRNZ
200318	1	PULLEY, V-BELT 4.78PD X 1.000 W/KEY
200665	1	CLUTCH ASSY, OGURA
200666	1	PLATE, CLUTCH DOG
200769	1	COVER, OPC
200770	1	WASHER, SPRING Y
200958	1	WHEEL HUB, MACHINED
200959	2	ASSY, REAR WHEEL HUB (Includes 20958 & 967370)
201009	1	BELT, HA 68.2 EL AMD OHR
201025	1	WLDT, RH BRAKE ARM
201027	1	WLDT, LH BRAKE SHAFT
201091	4	HOSE, HYD 1/2 X 26 1/2 EZFLEX
201353	1	WLDT, FRAME 34
201143	1	WLDT, IDLER PIVOT
201206	1	ABRASION SLEEVE
231046	2	FTG, ADP MJIC-FSWJIC 6500-08-08
231104	2	FTG, ADP 3/4-16FJIC X 7/8-14MOR
231647	2	FTG, ADP JIC-ORB 2062-10-8S
24M7158	2	SHIM, .020X.787X1.102
403490	1	SNAP RING, .750 X .042 EXT
959995	2	FTG, 1/4-28 STRGT GREASE ZERK
960022	2	BOLT, 5/16-18 X .750 HEX 5 Y
960025	3	BOLT, 5/16-18 X 1.50 HEX 5 Y
960026	1	BOLT, 5/16-18 X 1.75 HEX 5 Y
960046	10	BOLT, 3/8-16 X 1.00 HEX 5 Y
960049	1	BOLT, 3/8-16 X 1.75 HEX 5 Y
960052	1	BOLT, 3/8-16 X 2.50 HEX 5 Y
960055	1	BOLT, 3/8-16 X 3.25 HEX 5 Y
960078	1	BOLT, 7/16-14 X .750 HEX 5 Y
960502	1	NUT, 3/8-16 STD HEX GR5 Y
960602	1	WASHER, .375 MED SPRG LOCK Y
960702	3	WASHER, .375 REG FLAT Y
963020	2	BOLT, 3/8-16 X 1.00 CRG 5 Y
963033	2	Bolt, 3/8-16x3/4 Car Gr5 LNnk
963053	4	BOLT, 3/8-16 X 1.25 CRG 5 Y
964001	1	NUT, 3/8-16 JAM GR5 Y
964013	2	LOCKNUT, 10-24 NYLOC Y
967034	1	NUT, 5/16-18 JAM GR5 Y
967115	6	LOCKNUT, 5/16-18 NYLOC Y
967155	1	PIN, ROL .156 X 1.00
967340	2	SCREW, 10-24 X .625 PAN PHL MAC Y
967370	8	BOLT, 1/2-20 x 1.66 SPC
968087	12	LOCKNUT, 3/8-16 NYLOC Y
D18145	1	KEY, .250 X .250 X .995 TPR

FOOT PLATE/CONSOLE COMPONENTS

FOOT PLATE COMPONENTS

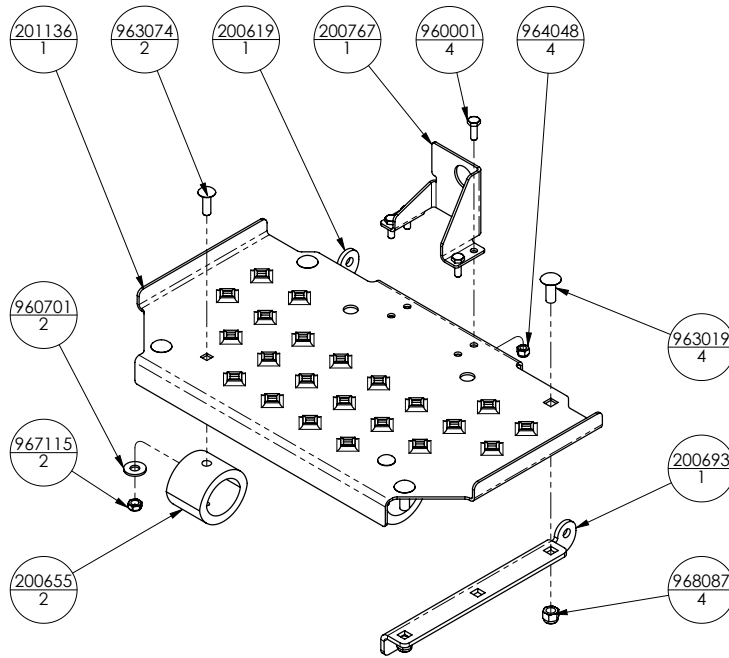

CONSOLE COMPONENTS

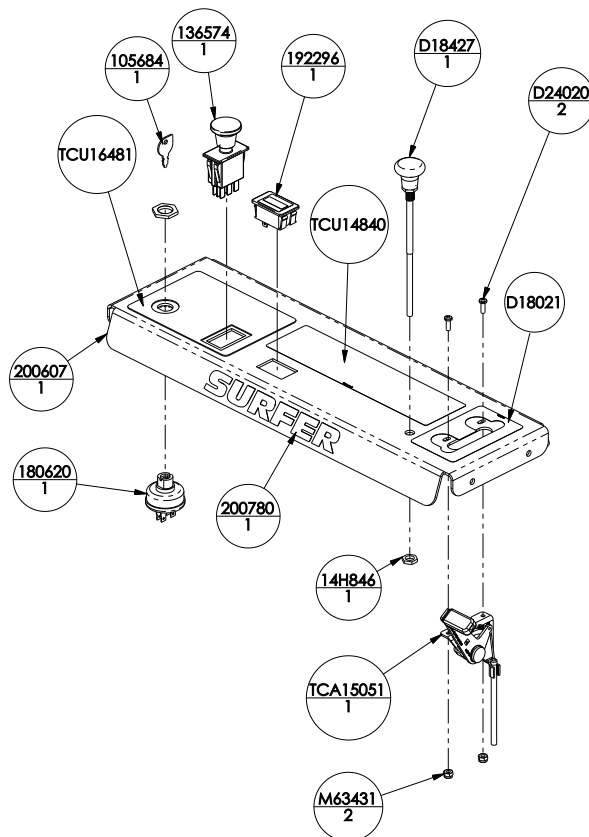

FOOT PLATE/CONSOLE COMPONENTS

FOOT PLATE COMPONENTS

PART NO	QTY	DESCRIPTION
200619	1	PLATE, PLATFORM TAB LH
200655	2	BUMPER, MINER GBR-6
200693	1	PLATE, PLATFORM TAB
200767	1	ANCHOR, OPC
201136	1	PLATFORM
960001	4	BOLT, 1/4-20 X .750 HEX 5 Y
960701	2	WASHER, .313 REG FLAT Y
963019	4	BOLT, 3/8-16 X 1.00 CRG 5 SN Y
963074	2	BOLT, 5/16-18 X 1.00 CRG 2 Y
964048	4	LOCKNUT, 1/4-20 NYLOC Y
967115	2	LOCKNUT, 5/16-18 NYLOC Y
968087	4	LOCKNUT, 3/8-16 NYLOC Y

CONSOLE COMPONENTS

PART NO	QTY	DESCRIPTION
D18021	1	DECAL, THROTTLE
D18427	1	CABLE, CHOKE
D24020	2	SCREW, 8-32X .50 PAN PHL Y
M63431	2	NUT, 8-32 ELASTIC STOP
TCA15051	1	CABLE, THROTTLE
TCU14840	1	DECAL, GENERAL CAUTION
TCU16481	1	DECAL, PTO & KEY SWITCH
105684	1	KEY
136574	1	SWITCH, PTO ENGAGEMENT
14H846	1	NUT, 3/8 UNF HEX GR 5 ZN
180620	1	SWITCH, KEY - 3 POSITION
192296	1	METER, HOUR - LCD ALT. (ENM)
200743	1	TOP, CONSOLE W/DECALS

DECK ASSEMBLY

PART NO	QTY	DESCRIPTION
D13024	2	SPACER, 1.500X1.000X.510 Y
D18032	1	PULLEY, FLAT 5.0X.38 W/BRG
D18055	6	WASHER, BLADE
D18076	2	BRG, FLG 1.00X1.25X1.00
D18084	1	PULLEY, SPLINE SPINDLE OFFSET
D18209	1	PULLEY, V-BELT 5.27X.990 W/SPL
D24019	2	WASHER, .402X2.00X.055 FEND Y
D23058	1	J-BOLT, 3/8-16 X 4.00 Y
GDA10103	1	PIVOT, RETAINER WELD
GDU10230	1	BLADE, 16.50 LO-LIFT
GDU10231	1	BLADE, 18"
H122207	1	NUT-1/4" FLANGE PREVAILING TOR
H141123	1	RETAINER #
M132768	1	SPRING,CHUTE GUARD
M119352	2	KNOB, LOCKING
N242189	1	SPRING, TENSION
TCA16387	1	CHUTE DISCHARGE ASST #
TCU18744	1	WHEEL, GAGE
200262	2	ASSY, SPINDLE HOUSING
201010	1	BELT, HB 80.3 EL AMD OHR
201145	1	WLDT, IDLER ARM
201350	1	WLDT, 34" DECK
201174	2	ASSY, FR WHEEL CASTER
201357	1	SHIELD, DECK 34
201178	1	WLDT, IDLER PIVOT
424390	1	SNAP RING, 1.00 X .042 EXT
959995	1	FTG, 1/4-28 STRGT GREASE ZERK
960046	16	BOLT, 3/8-16 X 1.00 HEX 5 Y
960051	1	BOLT, 3/8-16 X 2.25 HEX 5 Y
960502	12	NUT, 3/8-16 STD HEX GR5 Y
963019	3	BOLT, 3/8-16 X 1.00 CRG 5 SN Y
963095	1	BOLT, 1/4-20 X .750 CRG 5 Y
964016	17	LOCKNUT, 3/8-16 WHIZ Y
964022	1	LOCKNUT, 3/8-16 CROWN Y
964501	1	WASHER, .406 X .813 X .065 FLAT Y
967333	2	NUT, 3/4-16 FLANGE GR8 Y
967348	2	BOLT, 5/8-11 X 2.00 HEX 8 Y
968087	4	LOCKNUT, 3/8-16 NYLOC Y
999538	1	TRIM 1/4

WHEEL AND STRUT ASSEMBLY/PUMP COMPONENTS

WHEEL AND STRUT ASSEMBLY

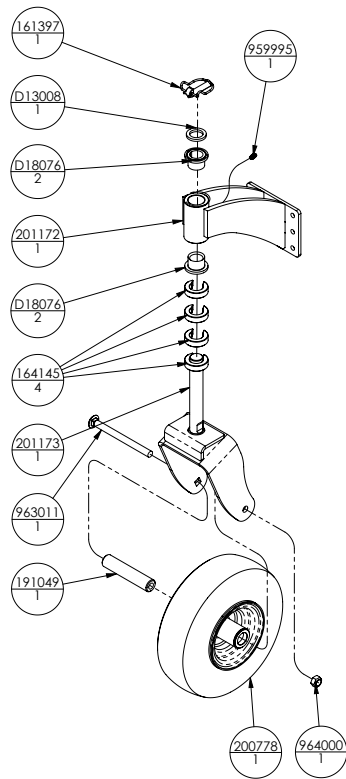

PUMP COMPONENTS

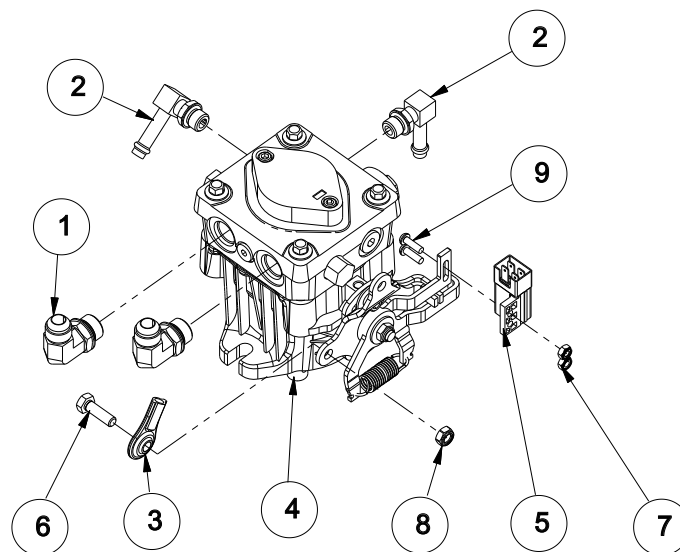

WHEEL AND STRUT ASSEMBLY/PUMP COMPONENTS

WHEEL AND STRUT ASSEMBLY

PART NO	QTY	DESCRIPTION
D13008	1	BUSHING, 1.03 X 1.50 X .179 Y
D18076	2	BRG, FLG 1.00X1.25X1.00
161397	1	PIN, LNC .438 X 2.00 Y
164145	4	C-SPACER, 1.00 X 1.77 X .500
191049	1	TUBE, RD 1.00X.500X4.76
200778	1	WHEEL, FRONT 11X4X5 SLV MIST
201172	1	WLDT, CASTER MOUNT BRACKET 34
201173	1	WLDT, FR WHEEL FORK
963011	1	BOLT, 1/2-13X6.00 CRG Y
964000	1	LOCKNUT, 1/2-13 CROWN Y
959995	1	FTG, 1/4-28 STRGT GREASE ZERK

PUMP COMPONENTS

ITEM	PART NO	QTY	DESCRIPTION
1	D14196	2	FTG, ADP JIC-ORB 6801-08-08
2	D24028	2	FTG, 90 9/16 MOR X 3/8 HOSE
3	D38157	1	ALIGNABALL, 5/16-24 RH THD
4	TCA14966	1	PUMP, RH HYDRO PG-1GRQ
	TCA14965	1	PUMP, LH HYDRO PG-1GRQ
5	191256	1	SWITCH, PLUNGER DP - N.O. - N.C.
6	960023	1	BOLT, 5/16-18 X 1.00 HEX 5 Y
7	964013	2	LOCKNUT, 10-24 NYLOC Y
8	967115	1	LOCKNUT, 5/16-18 NYLOC Y
9	967340	2	SCREW, 10-24 X .625 PAN PHL MAC Y
N/I	D19003	2	PUMP SEAL KIT

SPINDLE ASSEMBLY

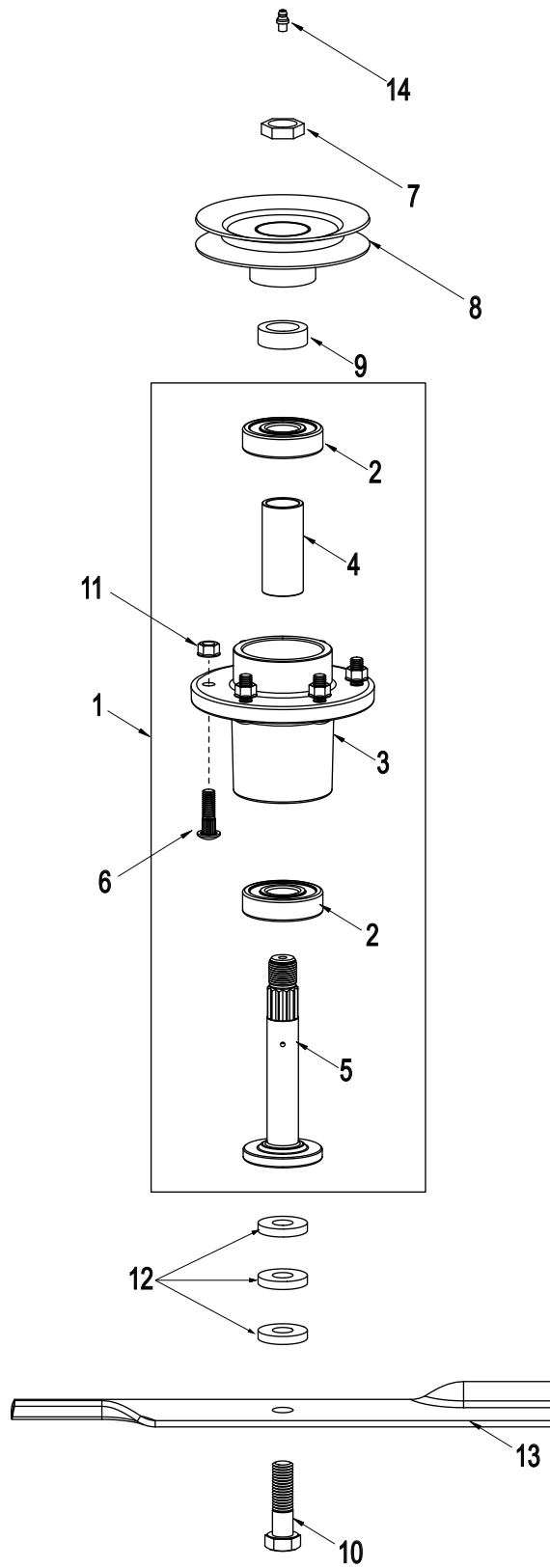

SPINDLE ASSEMBLY

ITEM	PART NO	QTY	DESCRIPTION
1	200262	1	Spindle Assembly - Includes items 2, 3, 4, 5, 6, 14
2	200046	2	Ball Bearing
3	200042	1	Housing
4	200044	1	Spacer - 1.000 x 1.250 x 2.772
5	200261	1	Shaft, Spindle
6	200045	6	Bolt, 3/8-16 x 1.25 Rib
7	967333	2	Nut, Pulley (Special)
8	N/A	2	Pulley, Cutter Housing - See Mower Assembly Pages
9	D13024	2	Spacer, Pulley
10	967348	2	Bolt, Blade - 5/8-11 x 2.00 Grade 8
11	960502	18	Nut, 3/8-16 Std Hex Gr5
12	D18055	6	Spacer, Blade Bolt
13	GDU10231	1	18.0" Blade, LH Deck
	GDU10230	1	16.5" Blade, RH Deck
14	200047	1	Zerk, Grease S/O

DECAL LOCATIONS

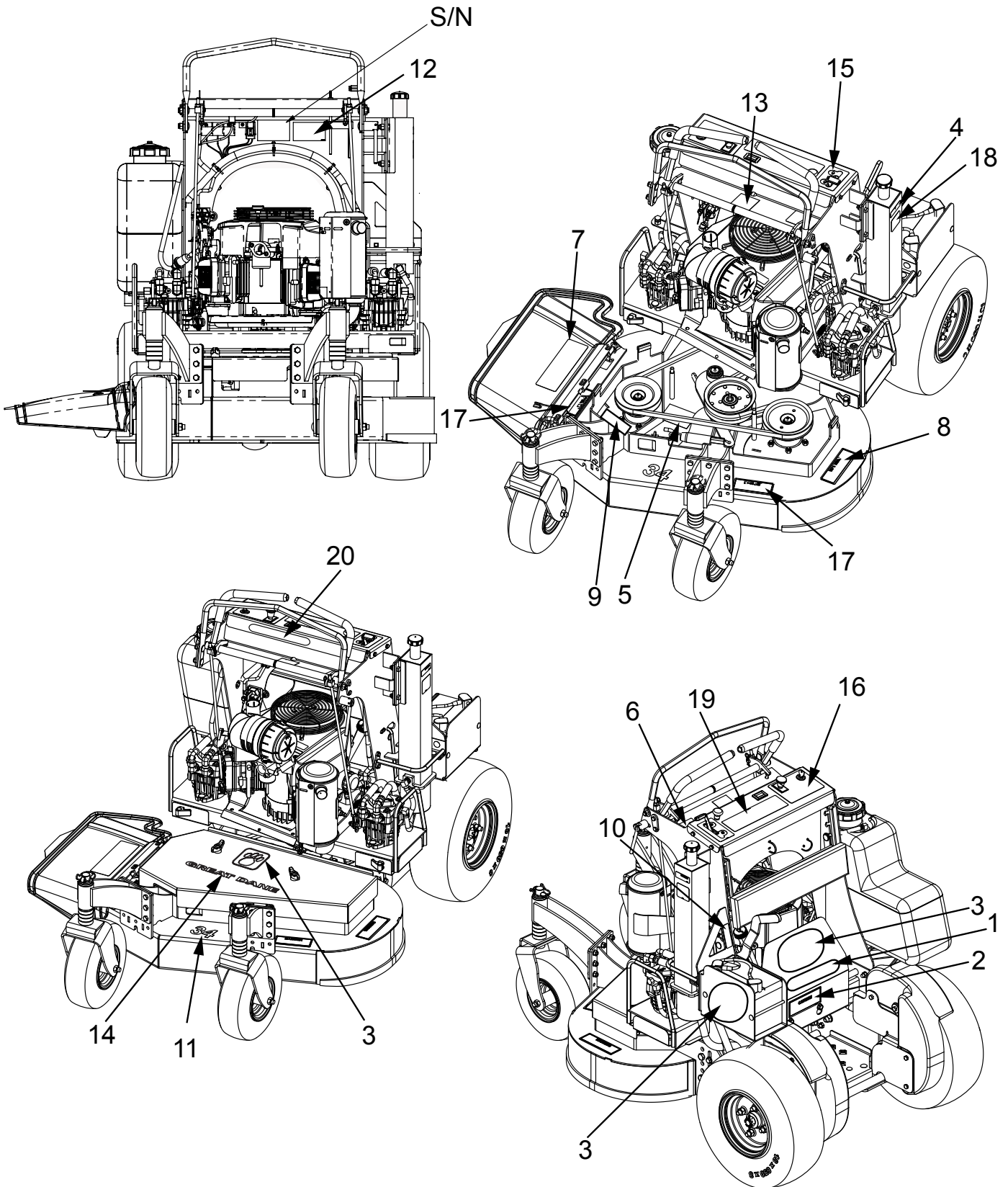

DECAL LOCATIONS

SURFER

1. D18197



2. D18372



3. GDU10256



4. M117554

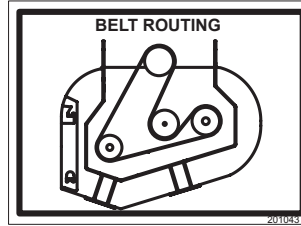

5. 201043



6. TCU15907



7. M137637

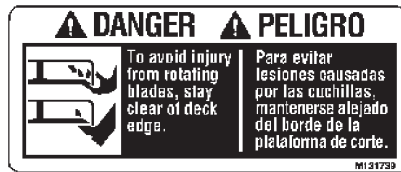

8. M131739



9. 160169



10. TCU16323

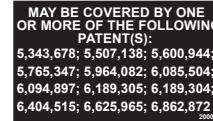

12. 200037

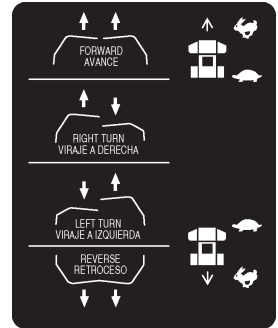

13. TCU15910

34

11. GDU10268

GREAT DANE

14. GDU10257

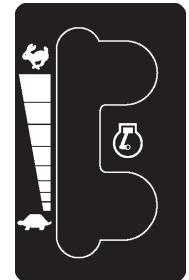

15. D18021

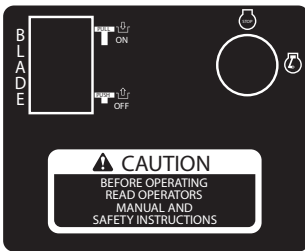

16. TCU16481



17. TCU51051



18. D18023



19. TCU14840

SURFER

20. 200780